



# PPD Series Portable Desiccant Compressed Air Dryer Packages

Models PPD0500 - PPD3000



ENGINEERING YOUR SUCCESS.

Page intentionally left blank

## Table of Contents

Section	Section Description	Page
<b>1.0</b>	<b>Safety Information</b>	4
<b>2.0</b>	<b>Description</b>	5
2.1	Stages of Purification	5
2.2	How to Order	6
2.3	Technical Specifications	7
2.4	Weights and Dimensions	7
2.5	Product Selection and Correction Factors	8
<b>3.0</b>	<b>Installation and Commissioning</b>	9
3.1	Receiving and Inspecting the Equipment	9
3.2	Recommended System Layout	9
3.3	General Mechanical Requirements	9
3.4	Environment	9
3.5	Space Requirements	9
3.6	Storage	10
<b>4.0</b>	<b>General Operation</b>	10
4.1	Overview of Equipment	11-13
4.2	Dryer Connections	14
4.3	Basic Controller	15
4.4	Advanced Controller	16
4.5	Timing Configurations	17
4.6	Purge Adjustment Settings & Charts	17-19
<b>5.0</b>	<b>Installation and Startup</b>	20
5.1	Shutdown	20-21
<b>6.0</b>	<b>Modbus Communications</b>	21
6.1	Modbus-RTU (Serial Port)	21-22
6.2	Modbus-TCP (Ethernet Port)	23
6.3	Modbus Register MAP	23
<b>7.0</b>	<b>Servicing</b>	24
7.1	Service Intervals	24
7.2	Spare Parts and Maintenance Kits List	25-26
<b>8.0</b>	<b>Troubleshooting</b>	28-29
<b>9.0</b>	<b>Flow Schematics</b>	30-33
<b>10.0</b>	<b>General Arrangement Drawings</b>	34-40
<b>11.0</b>	<b>Electrical Schematics</b>	41-42
<b>12.0</b>	<b>Disposal of Equipment</b>	43
12.1	Desiccant SDS	44-50

## 1.0 Safety Information

**Do not operate this equipment until the safety information and instructions in this user guide have been read and understood by all personnel concerned.**

### USER RESPONSIBILITY

FAILURE OR IMPROPER SELECTION OR IMPROPER USE OF THE PRODUCTS DESCRIBED HEREIN OR RELATED ITEMS CAN CAUSE DEATH, PERSONAL INJURY AND PROPERTY DAMAGE.

This document, and other information from Parker Hannifin Corporation, its subsidiaries or authorized distributors, provide product or system options for further investigation by users having technical expertise.

The user, through its own analysis and testing, is solely responsible for making the final selection of the system and components and assuring that all performance, endurance, maintenance, safety and warning requirements of the application are met. The user must analyze all aspects of the application, follow applicable industry standards, and follow the information concerning the product in the current product catalogue and in any other materials provided from Parker.

To the extent that Parker, its subsidiaries or authorized distributors provide component or system options based upon data or specifications provided by the user, the user is responsible for determining that such data and specifications are suitable and sufficient for all applications and reasonably foreseeable uses of the components or systems.

Only competent personnel trained, qualified, and approved by Parker Hannifin should perform installation, commissioning, service and repair procedures.

Use of the equipment in a manner not specified within this user guide may result in an unplanned release of pressure, which may cause serious personal injury or damage.

When handling, installing or operating this equipment, personnel must employ safe engineering practices and observe all related regulations, health & safety procedures, and legal requirements for safety.

Ensure that the equipment is depressurized and electrically isolated, prior to carrying out any of the scheduled maintenance instructions specified within this user guide.

Parker Hannifin cannot anticipate every possible circumstance which may represent a potential hazard. The warnings in this manual cover the most known potential hazards, but by definition cannot be all-inclusive. If the user employs an operating procedure, item of equipment or a method of working which is not specifically recommended by Parker Hannifin the user must ensure that the equipment will not be damaged or become hazardous to persons or property.

Most accidents that occur during the operation and maintenance of machinery are the result of failure to observe basic safety rules and procedures. Accidents can be avoided by recognizing that any machinery is potentially hazardous.

Should you require any technical support or training on this equipment, or any other equipment within the Parker Hannifin range, please contact Parker Hannifin Corporation.

### Factory Contact Information

Phone 1-716-686-6400

For pricing, availability, and purchase orders: [IGFGorders@parker.com](mailto:IGFGorders@parker.com)

For technical support and aftermarket: [GSFsupport@parker.com](mailto:GSFsupport@parker.com)

For product applications and technical sales: [FAFQuotes@parker.com](mailto:FAFQuotes@parker.com)



## 2.0 Description

Parker PPD Series Portable Desiccant Compressed Air Dryer packages are designed to filter and dehumidify compressed air to quality levels in accordance with the most widely used international standard, ISO8573-1. These all-inclusive compressed air treatment packages are assembled on a heavy duty, portable skid designed for long lasting durability and ease of transportation.

Equipped with dual coalescing pre-filters as standard, these systems remove harmful compressed air contaminants. These include: atmospheric particles, rust, pipe scale, microorganisms, water aerosols and oil aerosols. Following pre-filtration, the compressed air enters a twin tower desiccant dryer. Desiccant dryers remove water vapor and deliver a constant pressure dewpoint of -40°F (-40°C) or better to downstream equipment and/or processes. Once dried, the compressed air flows through a dry particulate after-filter to capture any desiccant dust that may attempt to flow downstream.

Optional: Parker PPD models 500-1600 can come equipped with an integrated air cooled after cooler with water separator package. This optional feature offers pre-cooling of the hot, saturated compressed air and bulk liquid (water & oil) separation prior to the compressed air entering the standard pre-filters.

For full operating details, see section 4.0 General Operation.

## 2.1 Stages of Purification

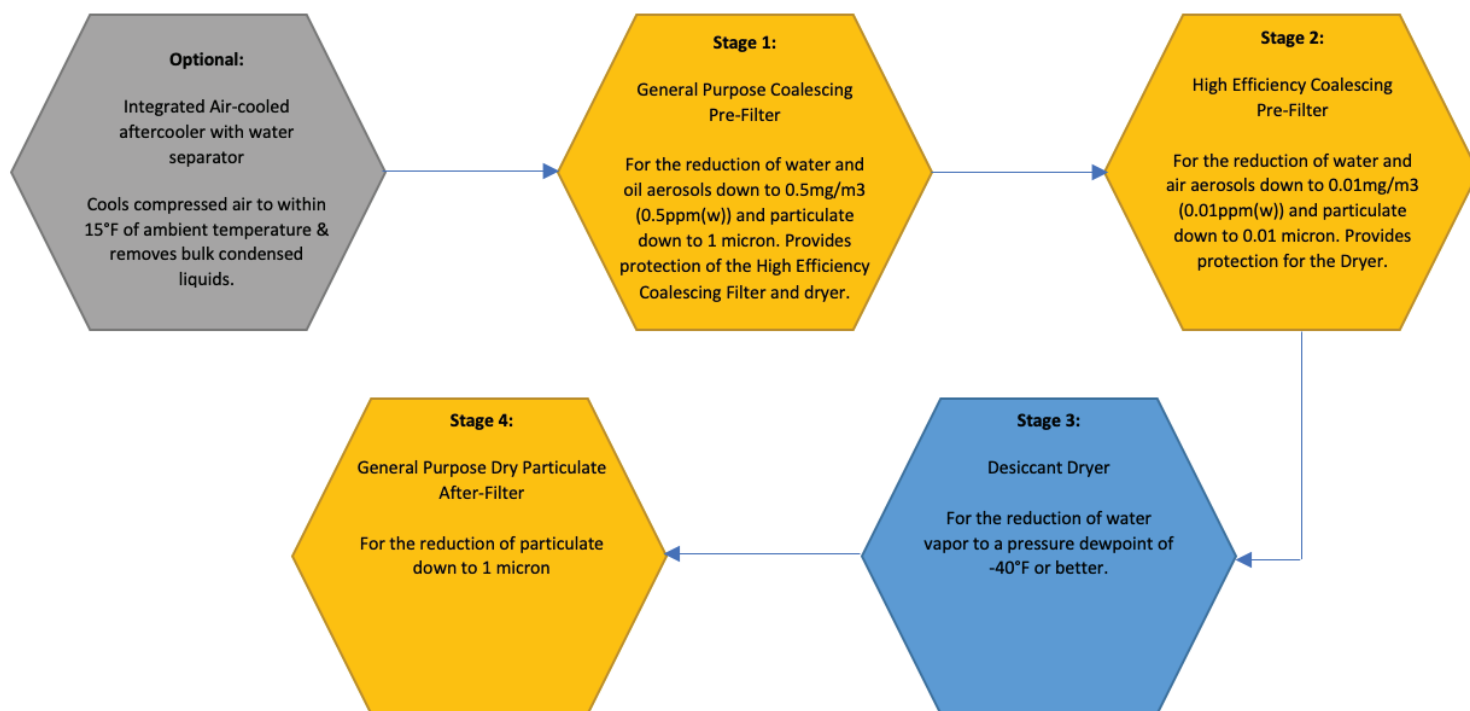

## 2.2 How to Order

Series	+	Flow Rate (scfm)	+	Controller Type		+	Pre-Treatment Options		=	Example
PPD		500		<b>B</b>	Basic PLC		<b>N</b>	No aftercooler package		PPD1600RA
		1000		<b>R</b>	Advanced PLC		<b>A</b>	Integrated aftercooler package & water separator		
		1600								
		3000								

### Basic PLC Controller (PPD0500-3000):

Controller Type:	Allen Bradley® PLC
Enclosure:	NEMA 4X
Panel:	Run/Stop switch, Power light, Run light, Stop light and Failure to Switch Alarm light
Hour meter:	Inside enclosure
Communication:	None
Dewpoint Sensor:	None
Dewpoint Display:	None

### Advanced PLC Controller (PPD0500-3000):

Controller Type:	Allen Bradley® PLC
Enclosure:	NEMA 4X
Panel:	Run/Stop switch, Power light, Run light, Stop light, Failure to Switch Alarm light, and High Dewpoint Alarm Light*
Hour meter:	Inside enclosure
Communication:	Modbus Ethernet Modbus RS485
Dewpoint Sensor:	Included
Dewpoint Display:	Digital, inside enclosure

### Integrated Aftercooler Option (PPD0500-1600):

Aftercooler Type:	Pneumatic, air-cooled
Aftercooler Approach:	15°F (within ambient temperature)
Lubricator Size:	64 oz.
Water Separator:	Included

\*High humidity alarm light on Advance PLC option illuminates once pressure dewpoint reaches >-20°F. Setpoint can be adjusted via communications port.

## 2.3 Technical Specifications

Model	Inlet Flow Rate <sup>1,2</sup>		Standard Pressure Dewpoint		Air In/Out	Air Motor Setting		Air Motor Loss		Lubrication Drip per Minute
	cfm	m3/hr	°F	°C		psi g	bar g	cfm	m3/hr	
PPD500*N	500	847	-40	-40	2" BOSS/NPT/FLG	N/A				
PPD500*A	500	847	-40	-40	2" BOSS/NPT/FLG	40	2.8	25	42	1
PPD1000*N	1000	1695	-40	-40	3" BOSS/NPT/FLG	N/A				
PPD1000*A	1000	1695	-40	-40	3" BOSS/NPT/FLG	50	3.5	70	119	2
PPD1600*N	1600	2712	-40	-40	3" BOSS/NPT/FLG	N/A				
PPD1600*A	1600	2712	-40	-40	3" BOSS/NPT/FLG	60	4.1	150	254	3
PPD3000*N	3000	5085	-40	-40	3" BOSS (x2) and 4" FLG	N/A				

Model	Min. Operating Pressure		Max. Operating Pressure		Max. Inlet Temperature		Min. Ambient Temperature <sup>4</sup>		Max. Ambient Temperature		Power Supply	Protection Class	Dryer FLA
	psi g	bar g	psi g	bar g	°F	°C	°F	°C	°F	°C			
PPD500-3000 No Aftercooler	80	5.5	150	10.3	120	49	40	4	120	49	120V 1Ph 50-60Hz	NEMA 4	2
PPD500-1600 With Aftercooler					250	121			105	41			

Notes:

1. Flow rate for PPD dryers WITHOUT aftercooler option models based on 100°F inlet, 100 psig inlet and 100°F ambient.
2. Flow rate for PPD dryers WITH aftercooler option models based on 250°F inlet, 100 psig inlet and 85°F ambient.
3. Designs for other flow rates, pressure and temperatures are available. Consult factory for additional information or to request a quote.
4. Proper freeze protection must be added to equipment operating in temperatures below 40°F. Consult factory for options.
5. PPD dryers come factory set for -40°F dewpoint as standard. Refer to section 4.6 Purge Adjustment Settings for necessary settings adjustments required to achieve dewpoints as low as -100°F.

## 2.4 Weights and Dimensions

Model	Height		Width		Depth		Weight	
	in	mm	in	mm	in	mm	lb	kg
PPD500*N	89.8	2281	53.9	1368	64.5	1638	2125	964
PPD500*A	89.8	2281	53.9	1368	64.5	1638	2325	1055
PPD1000*N	92.3	2343	70	1778	84.5	2146	3450	1565
PPD1000*A	92.3	2343	70	1778	84.5	2146	4000	1814
PPD1600*N	100.2	2545	84	2134	90.5	2299	5500	2495
PPD1600*A	100.2	2545	84	2134	90.5	2299	6200	2812
PPD3000*N	96.8	2459	98	2489	98	2489	10150	4604

Notes:

1. Weights and dimensions shown for all PPD models are approximate. Parker reserves the right to make changes without notification. Consult Parker for general arrangement drawings.

## 2.5 Product Selection and Correction Factors

See notes 1 & 2 in section 2.4 Technical Specifications regarding dryer flow rates and design conditions. Use the below correction factors for operating temperatures and pressures that differ from design conditions.

To obtain dryer flow capacity of PPD dryer WITHOUT integrated aftercooler option at new conditions, multiply: rated flow capacity x C1A x C2.

To obtain dryer flow capacity of PPD dryer WITH integrated aftercooler option at new conditions, multiply: rated flow capacity x C1B x C2.

Inlet Temperature Correction Factor								
Maximum Inlet Temperature (C1A)	°F	90	95	100	105	110	115	120
	°C	32	35	38	41	43	46	49
	CF	1.17	1.15	1.00	0.87	0.76	0.66	0.58

Ambient Temperature Correction Factor								
Maximum Inlet Temperature (C1B)	°F	75	80	85	90	95	100	105
	°C	32	35	38	41	43	46	49
	CF	1.17	1.15	1.00	0.87	0.76	0.66	0.58

Inlet Pressure Correction Factor								
Minimum Inlet Pressure (C2)	psi g	80	90	100	110	120	130	140
	bar g	5.5	6.2	6.9	7.6	8.3	9	9.7
	CF	0.83	0.91	1.00	1.09	1.17	1.26	1.29

**Example 1:** PPD500 without aftercooler, 90F inlet temperature and 130 psig inlet pressure:

$$\text{Rated Flow} \times \text{C1A} \times \text{C2} = \text{New flow capacity}$$

$$500 \text{ scfm} \times 1.17 \times 1.26 = 737 \text{ scfm}$$

**Example 2:** PPD1600 with aftercooler (and after cooler turned on), 90F ambient temperature, and 110 psi g inlet pressure.

$$\text{Rated Flow} \times \text{C1A} \times \text{C2} = \text{New flow capacity}$$

$$1600 \text{ scfm} \times 0.87 \times 1.09 = 1,517 \text{ scfm}$$



### 3.0 Installation and Commissioning

**WARNING:** Only competent personnel trained, qualified, and approved by Parker should perform installation, commissioning, service and repair procedures.

#### 3.1 Receiving and Inspecting the Equipment

On delivery of the equipment, check the system for damage. If there are any signs of damage to the system immediately contact Parker Hannifin Corporation or the authorized distributor that the equipment was purchased/rented through.

#### 3.2 Recommended System Layout

Parker's PPD Series Portable Desiccant Dryers filter and dehumidify compressed air; removing compressed air contaminants, which include: particulates (atmospheric dust, rust, pipe scale & microorganisms), water (liquid, aerosols and vapor) and oil (liquid & aerosols).

Parker's PPD Series Portable Desiccant Dryers are designed to be installed downstream of an air compressor. To connect the air compressor to the dryer, and the dryer to downstream equipment/processes, use interconnecting piping or hoses that meets the temperature and pressure requirements of the air compressor output.

It is recommended that an aftercooler be installed downstream of the air compressor and upstream of the desiccant dryer package. When sized properly, aftercoolers are typically designed to cool compressed air to within 15°F (+/- 5°F) of ambient temperature. Compressors without integrated aftercoolers can output compressed air temperatures >250°F. In these instances, a Parker PPD Series dryer with option for integrated air-cooled aftercooler and water separator (available on PPD0500-1600) should be utilized. If using a PPD Series dryer without the integrated aftercooler package, a standalone portable air-cooled aftercooler skid should be installed upstream of the dryer.

#### 3.3 General Mechanical Requirements

It is important to ensure that all piping materials are suitable for the application, and be clean and free of contaminants. The diameter of the pipe/hose must be sufficient to allow unrestricted inlet air supply to the equipment and outlet air supply to the application.

When installing the pipe/hose, ensure that they are adequately supported to prevent damage and leaks in the system.

All components used within the system must be rated to at least the maximum operating pressure of the equipment. It is recommended that the system be protected with suitably rated pressure relief valves.

#### 3.4 Environment

It is the users' responsibility to ensure that the environmental conditions specified for the equipment are maintained. Changes in temperature, humidity, and airborne pollution will affect the environment in which the equipment is operating and may impair the safety and operation. If operating in temperatures below 35°F, it is recommended that freeze protection be added to the equipment. Freeze protection must include heat trace, which will require a power source. **WARNING: The aftercooler cannot be used in freezing temperatures. Close the air motor air supply valve to stop operation. Ensure the aftercooler has been drained and is free from any liquid condensate.**

#### 3.5 Space Requirements

The equipment should be installed on a flat surface capable of supporting its own weight plus the weight of all ancillary parts. The minimum footprint requirements are specified in section 2.5, however there must be adequate space around the equipment to allow airflow and access for maintenance purposes and lifting equipment. A minimum spacing of approximately 4 feet is recommended around all sides of the unit and above it.

### 3.6 Storage

When storing, ensure the equipment in a location that is safe and protected from the surrounding environment. If stored outdoors, it is recommended that the equipment be underneath a shelter, shrink wrapped or crated to protect against direct sunlight and contact with the elements. If stored in a location exposed to freezing temperatures, all drains must be emptied, including the aftercooler drain. All plugs and flange covers should remain in place until the dryer is ready to be installed.

### 4.0 General Operation

Hot, saturated compressed air flows into the desiccant dryer package and is treated by the following stages:

**[Optional Stage] Air-cooled aftercooler and water separator:** The compressed air passes through a Y-strainer where unwanted solids are removed from the gas stream. Then, the air-cooled aftercooler uses ambient air to cool the hot, saturated compressed air to within 15°F of ambient temperature. As a result of the cooling, water in the compressed air condenses. Next, the air flows through a centrifugal water separator, which removes bulk condensed liquid from the compressed air.

**[Stage 1] Pre-Filter 1 – General Purpose Coalescing Filter:** Coalescing filters are the most important items of a compressed air treatment system. They are designed to remove aerosols (very fine droplets or mist) of oil & water and solid particulates (such as dirt, rust, pipe scale and microorganisms). This general-purpose coalescing filter reduces water and oil aerosols down to 0.5mg/m<sup>3</sup> (0.5ppm(w)) and particulate down to 1 micron. Provides protection of the High Efficiency coalescing filter and desiccant dryer.

**[Stage 2] Pre-Filter 2 – High Efficiency Coalescing Filter:** Reduces water and oil aerosols down to 0.01mg/m<sup>3</sup> (0.01ppm(w)) and particulate down to 0.01 micron. Provides a high-level of protection for the desiccant dryer.

**[Stage 3] Twin Tower Desiccant Dryer:** Desiccant dryers remove water vapor by passing wet air over a bed of adsorbent desiccant material. Water will always migrate from the driest medium and transfers from the wet air to the dry desiccant. The desiccant material has a large internal capacity to hold water vapor. However, the desiccant material has a fixed adsorption capacity. Once the adsorption capacity is reached, it must be regenerated.

To continuously supply dry air, the desiccant dryer utilizes two vessels filled with desiccant material. During operation, one vessel is “on-line” drying the compressed air while the other is “off-line” undergoing regeneration. The air flow is periodically switched between the two vessels to allow for the saturated bed to regenerate.

Parker’s PPD Portable Desiccant Compressed Air Dryers use a regeneration method called Pressure Swing Adsorption (PSA) or Heatless Regeneration. At time of changeover, the saturated vessel exhausts to atmosphere and depressurizes to atmospheric pressure. Next, approximately 15% of the dried process air (known as purge air) from the dry air outlet is diverted to the “off-line” vessel and passes over the wet desiccant bed. The dried process air sweeps away the water vapor and is exhausted to atmosphere.

Important! The dryer is designed to remove only water vapor. Users’ may see a small amount of condensate forming at the exhaust due to the Joule-Thomson cooling effect created by the depressurizing air.

Prior to switching a newly regenerated bed to “on-line” it must be slowly pressurized from atmospheric pressure to line pressure. This step is called repressurization. This prevents bed fluidization (lifting) and associated desiccant dusting.

Desiccant dryers operate on a fixed time cycle. Once started up, the dryer will continuously purge (except during repressurization) and the vessels will continuously switch back and forth until the dryer is shutdown.

**[Stage 4] After-Filter 1 – General Purpose Dry Particulate Filter:** Due to the nature of pressure swing adsorption dryers, it is common for the desiccant material to slowly break down. The dry particulate after-filter captures the desiccant dust ensuring clean, dry air to downstream equipment/processes.

**Note: All condensate from the optional water separator and standard compressed air filters is removed via automatic condensate drains.**

**IMPORTANT:** Should you require any technical support or training on this equipment prior to operating, please contact Parker Hannifin Corporation or the authorized distributor this equipment was purchased/rented through.

## 4.1 Overview of Equipment

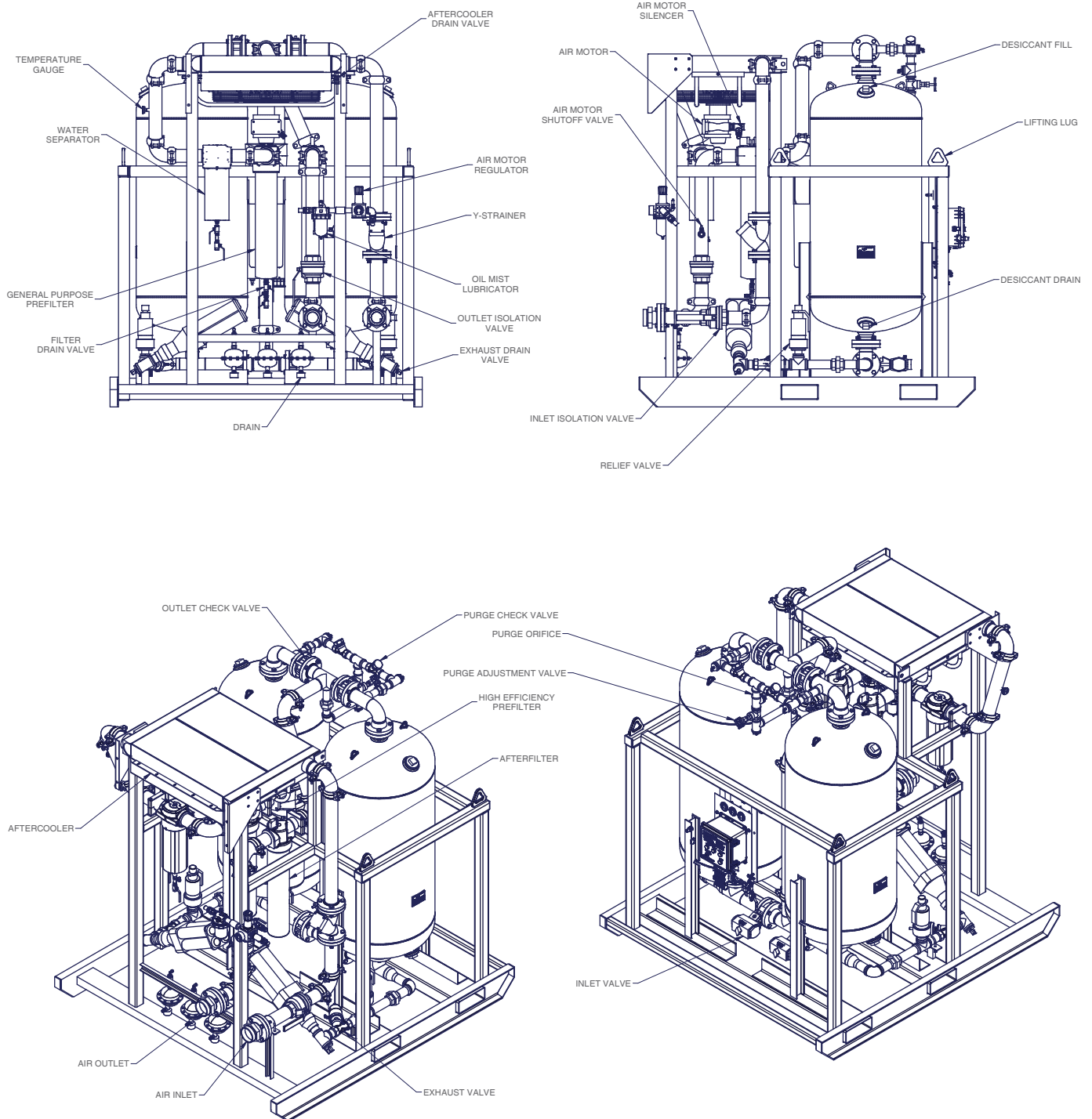

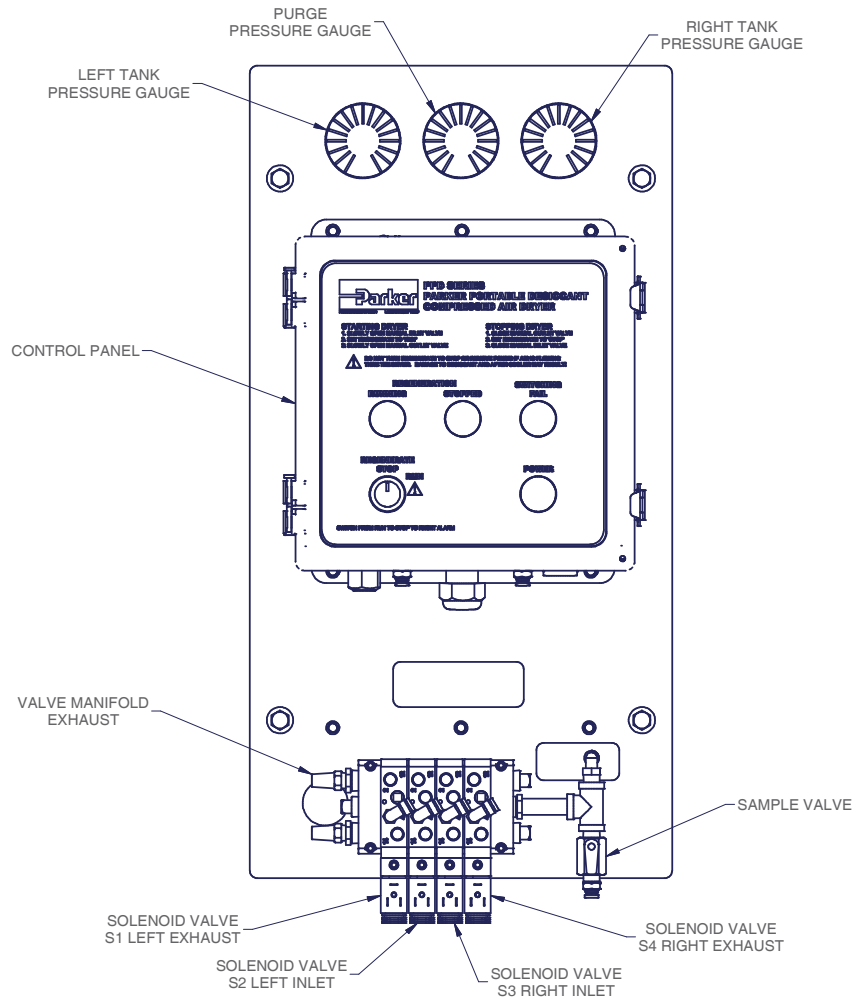

### 4.1 Overview of Equipment (Continued)

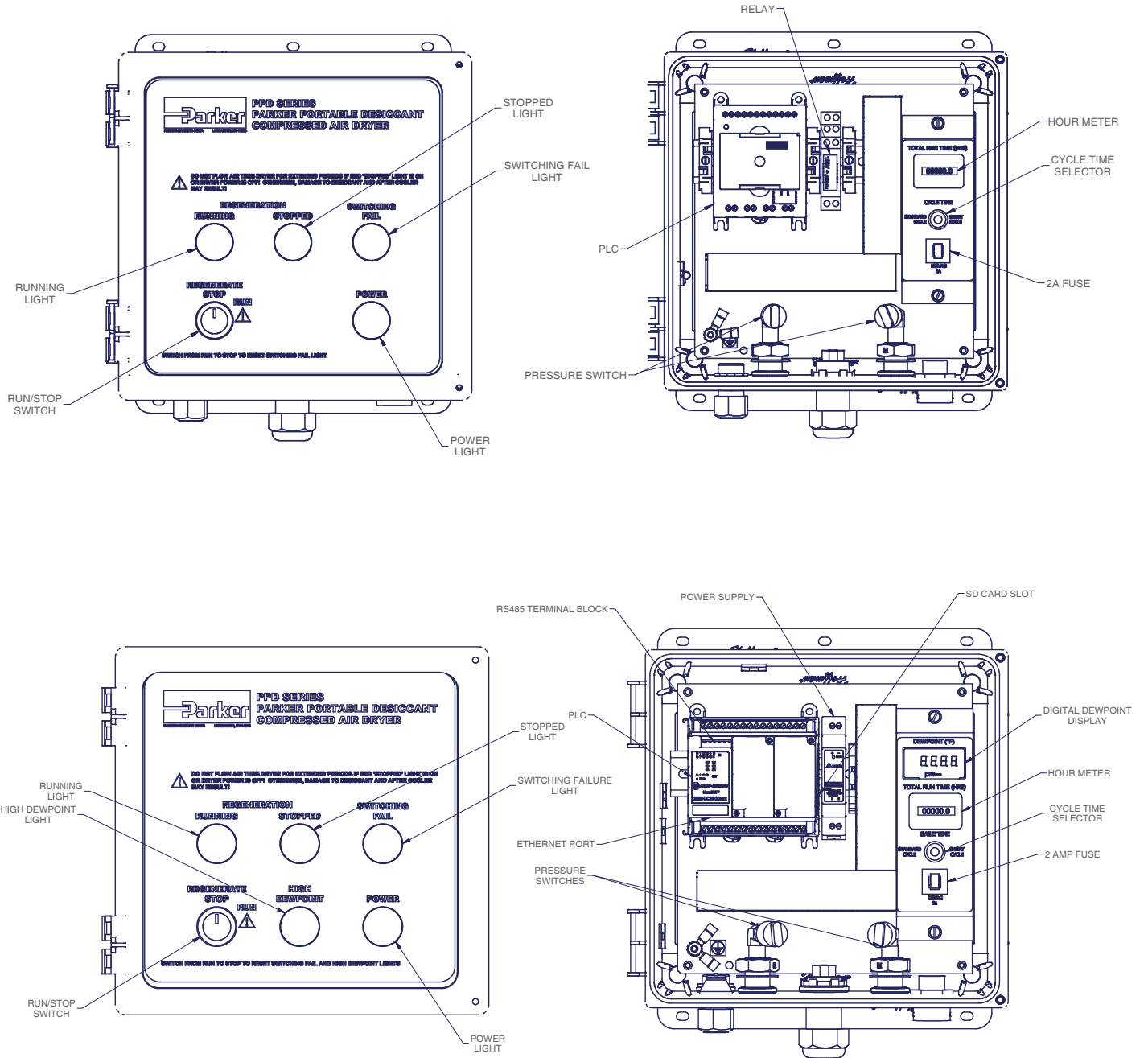

## 4.2 Dryer Connections

There are several connection points on the dryer. Make sure each connection is made prior to startup.

- 1. Air in connection** – Will be marked on the dryer with a tag. Use piping/hosing suitable for the pressure and temperature class.
- 2. Air out connection** – Will be marked on the dryer with a tag. Use piping/hosing suitable for the pressure and temperature class.
- 3. Drain connections** – Located at the skid edge and labeled. Drain discharge is under pressure equal to the system and must use piping/hosing suitable for the pressure and temperature class if piped to another location. It is critical to the performance of the dryer to protect the desiccant bed from oil and bulk moisture contamination. Proper maintenance of filters and drains is required.
- 4. Power supply** – Use power cable provided. Verify voltage and frequency of power supply matches the dryer design by checking the serial label.
- 5. Exhaust mufflers** – Mufflers are included with the dryer to reduce noise level only. They are not required for normal operation and should not be installed for initial startup or after a desiccant changeout. The exhaust may be piped to another location to further reduce noise but must not restrict purge air or dryer performance will suffer. The following considerations must be taken when piping the exhaust:

**TO 10 FEET, SAME PIPE DIAMETER SIZE AS DRYER EXHAUST VALVE**

**TO 25 FEET, ONE PIPE DIAMETER SIZE LARGER THAN DRYER EXHAUST VALVE**

**TO 50 FEET, TWO PIPE DIAMETER SIZES LARGER THAN DRYER EXHAUST VALVE**

**TO 100 FEET, THREE PIPE DIAMETER SIZES LARGER THAN DRYER EXHAUST VALVE**

Each elbow installed in the exhaust piping is equivalent to 10 feet of pipe. If the exhaust piping is vertical, a drip line must be installed to remove moisture. It is recommended to pipe the exhausts separately for ease of maintenance and troubleshooting.

### 4.3 Basic Controller

The basic dryer controller consists of a PLC, cycle time selector, run/stop switch, indicator lights, and hour meter. The PLC is programmed to operate the switching valves on the user selected time setting for automatic switching of the dryer tanks.

**RUNNING Indicator** – The RUNNING indicator will illuminate while the dryer switch is in RUN position and indicates that the dryer is regenerating and the cycle time sequence has resumed. Valves will switch.

**STOPPED Indicator** – The STOPPED indicator will illuminate while the dryer switch is in the STOP position and indicates that regeneration has stopped and the cycle time sequence has paused. Valves will not switch.

**POWER Indicator** – The POWER indicator will illuminate when the dryer 120V power source is hooked up.

**RUN/STOP switch** – The RUN/STOP switch removes power to the PLC controller and valves when set to STOP. Always startup the dryer with the switch in the STOP position. The dryer timing sequence will be paused, and valves will not switch while in this state. Air will continue to flow through the dryer. By switching to RUN, the timing cycle will begin where it left off and continue to open and close valves to switch drying tanks as the dryer proceeds through the cycle.

**WARNING! Do not run air through the dryer for extended times if it is powered off or regeneration switch is set to stop. Damage to desiccant or after cooler may result.**

**SWITCHING FAIL Indicator** - illuminates during a failure to switch alarm condition and remain lit until it is reset. The alarm will occur under the following conditions:

- The tower is not above 65 psig at the end of repressurization
- The regenerating tower is not less than 25 psig during regeneration
- The drying tower drops below 25 psig any time after a successful blowdown

If the dryer fails to repressurize within 40 seconds, an alarm will occur. Air will continue to pass through the same drying tank until 10 seconds after the regenerating tank reaches 65 psig at which point it will switch towers.

The latest alarm condition is stored and maintained until both towers have successfully regenerated. Upon reset, the SWITCHING FAIL light indicator will blink depending on the latest alarm condition:

- 1 time – Failed to Blowdown Left Tower in 15 seconds
- 2 times – Failed to Blowdown Right Tower in 15 seconds
- 3 times – Failed to Repressurize Left Tower in 40 seconds
- 4 times – Failed to Repressurize Right Tower in 40 seconds
- 5 times – Switch opened during drying left
- 6 times – Switch opened during drying right

The SWITCHING FAIL indicator can be manually reset by switching from RUN to STOP.

The SWITCHING FAIL indicator will automatically reset after both sides successfully regenerate 144 times (24 hours in standard cycle time mode).

Failure to switch alarm condition monitoring are ignored until one or both towers reaches 65 psig.

**Cycle Time Selector** – Located inside the enclosure. The user may toggle between two operating cycles. Select “Standard Cycle” for a ten-minute cycle to operate the dryer at its specified design conditions. Select “Short Cycle” to operate the dryer on a four-minute cycle. See Section 4.6 Purge Adjustment Settings for details on using short cycle mode to achieve dewpoints better than -40°F and as low as -100°F.

**Hour Meter** – Located inside the enclosure. Displays the number of hours the dryer is in the RUN mode of operation.

## 4.4 Advanced Controller

The advanced controller consists of a PLC and includes all the same features as the basic controller plus a digital dewpoint display, high dewpoint alarm indicator, and remote communications capabilities.

**RUNNING Indicator** – The RUNNING indicator will illuminate while the dryer switch is in RUN position and indicates that the dryer is regenerating and the cycle time sequence has resumed. Valves will switching.

**STOPPED Indicator** – The STOPPED indicator will illuminate while the dryer switch is in the STOP position and indicates that regeneration has stopped and the cycle time sequence has paused. Valves will not switch.

**POWER Indicator** – The POWER indicator will illuminate when the dryer 120V power source is hooked up.

**RUN/STOP switch** – The RUN/STOP switch pauses regeneration when the switch is set to STOP. Always startup the dryer with the switch in the STOP position. The dryer timing sequence will be paused, and valves will not switch while in this state. Air will continue to flow through the dryer. By switching to RUN, the timing cycle will begin where it left off and continue to open and close valves to switch drying tanks as the dryer proceeds through the cycle.

**WARNING! Do not run air through the dryer for extended times if it is powered off or regeneration switch is set to stop. Damage to desiccant or after cooler may result.**

**HIGH DEWPOINT Indicator** – Illuminates when dryer outlet dewpoint is worse than -20°F and is automatically reset when alarm condition is not present. Dryer will continue to cycle as normal while alarm is active. Setpoint may be changed by accessing network via MODBUS communications.

**SWITCHING FAIL Indicator** - Illuminates during a failure to switch alarm condition and remains lit until alarm is reset is reset. The alarm will occur under the following conditions:

- The tower is not above 65 psig at the end of repressurization
- The regenerating tower is not less than 25 psig during regeneration
- The drying tower drops below 25 psig any time after a successful blowdown

If the dryer fails to repressurize within 40 seconds, an alarm will occur. Air will continue to pass through the same drying tank until 10 seconds after the regenerating tank reaches 65 psig at which point it will switch towers.

The latest alarm condition is stored and maintained until both towers have successfully regenerated.

Upon reset, the SWITCHING FAIL light indicator will blink depending on the latest alarm condition:

- 1 time – Failed to Blowdown Left Tower in 15 seconds
- 2 times – Failed to Blowdown Right Tower in 15 seconds
- 3 times – Failed to Repressurize Left Tower in 40 seconds
- 4 times – Failed to Repressurize Right Tower in 40 seconds
- 5 times – Pressure drops in left drying tower
- 6 times – Pressure drops in right drying tower

The SWITCH FAIL indicator can be manually reset by switching from RUN to STOP.

The SWITCH FAIL indicator will automatically reset after both sides successfully regenerate 144 times (24 hours in standard cycle time mode).

Failure to switch alarm condition monitoring are ignored until one or both towers reaches 65 psig.

**DIGITAL DEWPOINT display** – Located inside enclosure. Displays dryer outlet dewpoint in °F.

**CYCLE TIME SELECTOR** – Located inside the enclosure. The user may toggle between two operating cycles. Select “Standard Cycle” for a ten-minute cycle to operate the dryer at its specified design conditions. Select “Short Cycle” to operate the dryer on a four-minute cycle. See Section 4.6 Purge Adjustment Settings for details on using short cycle mode to achieve dewpoints better than -40°F and as low as -100°F.

**HOURLY METER** – Located inside the enclosure. Displays the number of hours the dryer is in the RUN mode of operation.



### 4.5 Timing Configuration

The control system allows the user to select two different timing configuration modes: Standard Cycle and Short Cycle. Below outlines the timing configurations (in seconds) for both modes. Standard Cycle Mode should be used for achieving design pressure dewpoint of -40°F (-40°C). Short Cycle Mode can be used to achieve pressure dewpoints lower than -40°F (-40°C).

### TIMING CHART

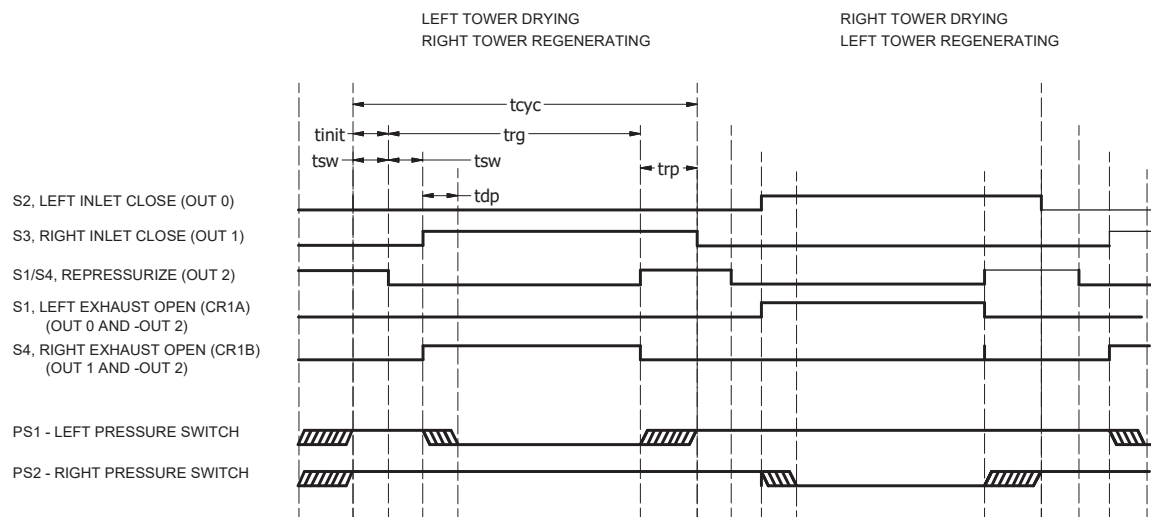

		Standard	Short
Cycle time	tcyc	300	120
Regeneration	trg	260	80
Repressurization	trp	40	40
Depressurization	tdp	15	15
Inlet Close Delay	tsw	2	2
Initialization	tinit	40	40

### 4.6 Purge Adjustment Settings & Charts

PPD Dryers feature an adjustable purge flow system, which consists of the following components:

1. Purge adjustment valve
2. Purge pressure gauge
3. Purge orifice

Refer to Section 4.1 Overview of Equipment for locations of the aforementioned components. The purpose of the adjustable purge flow system is to regulate the amount of purge air flow required to properly regenerate the off-line tower, deliver optimal outlet dewpoint and minimize energy consumption. The amount of compressed air flow through the purge orifice is controlled by adjusting the purge adjustment valve to a specific pressure setting on the purge pressure gauge. The purge pressure setting varies on the dryer model, operating flow, operating pressure and desired pressure dewpoint (Pdp). To determine the purge pressure setting, use the cross-sectional tables below by identifying the operating flow and pressure for the PPD dryer model being used.

There are tables for standard dewpoint (-40°F Pdp), which requires operation with ‘Standard Cycle’ mode enabled. There are tables for low dewpoint (as low as -100°F Pdp), which requires operation with ‘Short Cycle’ mode enabled.

## Pressure Setting (psig) for -40°F Dewpoint

**IMPORTANT** - Dryers will not achieve dewpoint immediately following start up. Desiccant dryers adsorb atmospheric moisture even when not in use (i.e. during shipping, sitting idle in yard, etc.). Following installation, commissioning and initial operation, a dryer's desiccant beds will begin to slowly "dry down" as the dryer cycles back and forth. When set to a purge pressure setting for -40°F dewpoint and operating in Standard Cycle Mode, the -40°F dewpoint will be achieved with a couple of hours.

PPD0500 Pressure Setting (psig) for -40°F Dewpoint								
Flow Rate (scfm)	Operating Pressure							
	80 psig	90 psig	100 psig	110 psig	120 psig	130 psig	140 psig	150 psig
250	30	30	30	30	30	30	30	30
300	35	30	30	30	30	30	30	30
400	51	40	30	30	30	30	30	30
500	68	53	42	33	30	30	30	30

PPD1000 Pressure Setting (psig) for -40°F Dewpoint								
Flow Rate (scfm)	Operating Pressure							
	80 psig	90 psig	100 psig	110 psig	120 psig	130 psig	140 psig	150 psig
500	35	35	35	35	35	35	35	35
600	42	35	35	35	35	35	35	35
700	51	39	35	35	35	35	35	35
800	60	46	36	35	35	35	35	35
900	70	54	43	35	35	35	35	35
1000	79	62	49	39	35	35	35	35

PPD1600 Pressure Setting (psig) for -40°F Dewpoint								
Flow Rate (scfm)	Operating Pressure							
	80 psig	90 psig	100 psig	110 psig	120 psig	130 psig	140 psig	150 psig
1000	45	35	35	35	35	35	35	35
1100	51	39	35	35	35	35	35	35
1200	57	44	35	35	35	35	35	35
1300	63	49	38	35	35	35	35	35
1400	69	54	42	35	35	35	35	35
1500	75	59	47	37	35	35	35	35
1600	80	64	51	40	35	35	35	35

PPD3000 Pressure Setting (psig) for -40°F Dewpoint								
Flow Rate (scfm)	Operating Pressure							
	80 psig	90 psig	100 psig	110 psig	120 psig	130 psig	140 psig	150 psig
1600	25	25	25	25	25	25	25	25
1800	27	25	25	25	25	25	25	25
2000	32	25	25	25	25	25	25	25
2200	37	27	25	25	25	25	25	25
2400	41	31	25	25	25	25	25	25
2600	46	35	27	25	25	25	25	25
2800	51	39	30	25	25	25	25	25
3000	55	43	33	26	25	25	25	25



## Low Dewpoint Pressure Setting for Dewpoints as low as -100°F

**IMPORTANT** - Dryers will not achieve dewpoint immediately following start up. Desiccant dryers adsorb atmospheric moisture even when not in use (i.e. during shipping, sitting idle in yard, etc.). Following installation, commissioning and initial operation, a dryer's desiccant beds will begin to slowly "dry down" as the dryer cycles back and forth. When set to a purge pressure setting for low dewpoint and operating in Short Cycle Mode, the dryer will achieve a dewpoint better than -40°F and as low as -100°F. The dry down period may take several weeks of continuous operation and thousands of cycles to achieve the lowest possible dewpoint.

PPD0500 Pressure Setting (psig) for dewpoints as low as -100°F								
Flow Rate (scfm)	Operating Pressure							
	80 psig	90 psig	100 psig	110 psig	120 psig	130 psig	140 psig	150 psig
250	30	30	30	30	30	30	30	30
300	53	41	31	30	30	30	30	30
400	75	59	47	38	30	24	19	15
500	N/A	78	62	51	41	34	28	22

PPD1000 Pressure Setting (psig) for dewpoints as low as -100°F								
Flow Rate (scfm)	Operating Pressure							
	80 psig	90 psig	100 psig	110 psig	120 psig	130 psig	140 psig	150 psig
500	49	37	35	35	35	35	35	35
600	61	48	37	35	35	35	35	35
700	74	58	46	36	35	35	35	35
800	N/A	68	55	44	36	35	35	35
900	N/A	79	63	51	42	35	35	35
1000	N/A	89	72	58	48	40	35	35

PPD1600 Pressure Setting (psig) for dewpoints as low as -100°F								
Flow Rate (scfm)	Operating Pressure							
	80 psig	90 psig	100 psig	110 psig	120 psig	130 psig	140 psig	150 psig
1000	66	52	41	35	35	35	35	35
1100	75	58	46	37	35	35	35	35
1200	N/A	65	52	42	35	35	35	35
1300	N/A	72	57	46	37	35	35	35
1400	N/A	78	63	51	42	35	35	35
1500	N/A	N/A	68	56	45	37	35	35
1600	N/A	N/A	74	60	50	41	35	35

PPD3000 Pressure Setting (psig) for dewpoints as low as -100°F								
Flow Rate (scfm)	Operating Pressure							
	80 psig	90 psig	100 psig	110 psig	120 psig	130 psig	140 psig	150 psig
1600	25	25	25	25	25	25	25	25
1800	27	25	25	25	25	25	25	25
2000	32	25	25	25	25	25	25	25
2200	37	27	25	25	25	25	25	25
2400	41	31	25	25	25	25	25	25
2600	46	35	27	25	25	25	25	25
2800	51	39	30	25	25	25	25	25
3000	55	43	33	26	25	25	25	25

## 5.0 Installation and Startup

1. Install equipment on level surface with 4 ft. clearance on all sides and above dryer.

 **Add heat trace and insulation to dryer if exposed to freezing temperatures.**

2. Close dryer inlet isolation valve (**labeled MV1**) and outlet isolation valve (**labeled MV2**).
3. Open dryer control air valve (**labeled MV3**).
4. **Aftercooler Only!** Ensure after-cooler oil mist lubricator (**labeled ML1**) is filled.
5. **Aftercooler Only!** Open the after-cooler air motor valve (**labeled MV13**).
6. Connect compressor discharge to dryer air inlet port (**labeled INLET**).
7. Connect downstream equipment to dryer air outlet port (**labeled OUTLET**).

 **Use properly rated hoses for all connections and whip checks on all hoses for safety.**

8. Set the dryer **RUN/STOP** switch to **STOP**.
9. Supply power to dryer using 120 VAC power cable. **POWER** and **STOP** lights will illuminate on dryer control panel.

 **DO NOT START THE DRYER AT THIS TIME.**

10. Verify all hoses, piping and electrical connections to and from dryer are secure.
11. **START** compressor.
12. Partially open dryer inlet isolation valve (**labeled MV1**) to slowly pressurize dryer.
13. Once dryer is at line pressure, fully open inlet valve (**labeled MV1**).
14. **Aftercooler Only!** Adjust motor pressure regulator (**labeled PR2**) to pressure setting stated on label.
15. Set dryer **RUN/STOP** switch to **RUN**. **RUNNING** light will illuminate on dryer control panel.
16. Set dryer purge pressure adjustment valve (**labeled PR1**) according to below chart.

 **Purge pressure can only be set during regeneration (one tank at line pressure, one tank at 0 psi g).**

17. Partially open outlet isolation valve (**labeled MV2**) to slowly pressurize downstream equipment.

 **If system fails to pressurize, check downstream leaks and valves.**

16. Once downstream equipment is at line pressure, fully open outlet valve (**labeled MV2**).

 **Aftercooler Only!** When dryer is in use, periodically check sight glass on the oil mist lubricator (**labeled ML1**) and fill as needed. After use, ensure the aftercooler is completely drained by opening drain valve (**labeled MV14**). Freezing temperatures can cause damage to aftercooler if not drained properly.

### 5.1 Shutdown

Slowly close rental dryer inlet and outlet isolation valves.

Allow aftercooler and dryer to continue to run. The normal cycle will allow both dryer desiccant vessels to blowdown to low levels of pressure.

Stop regeneration using the **RUN/STOP** switch located on the front of the control panel enclosure. Disconnect power supply.

Slowly open the manual drain valve on the after-filter to allow full depressurization of the dryer.

Verify all pressure is removed from equipment and power is disconnected before servicing or uninstalling. If preparing for storage or extended downtime, open each manual drain valve for each filter, water separator, aftercooler, and exhaust valves to allow all condensate to drain. **WARNING: Failure to do so can lead to damage of equipment during freezing temperatures.**

## 6.0 Modbus Communications

The Advanced PLC Controller supports both MODBUS-RTU and MODBUS-TCP communications protocols.

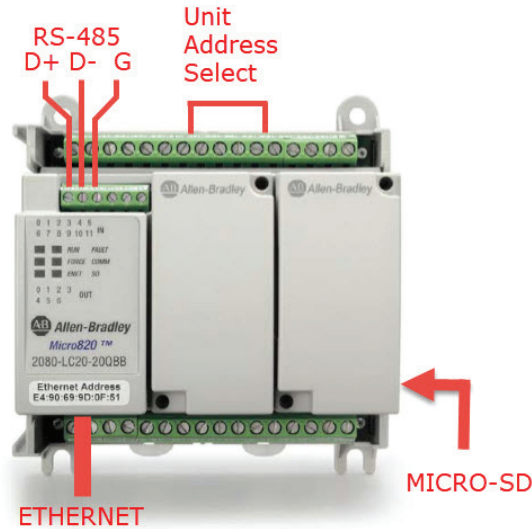

### 6.1 Modbus-RTU (Serial Port)

The Serial Port comes standard set as follows. Consult the factory for other configurations

Media:	RS-485
Modbus Local Address:	1 (Default is 1, Range is 1 through 15)
Baud Rate:	19200
	8 Bits
Parity:	None
Stop Bits:	1

The serial port is not isolated. Necessary precautions should be taken to minimize noise in high noise environments. An external RS485 isolator may be necessary in extreme circumstances or where extreme differences in ground potential between the master and slave devices may exist.

Unit Address Selection – PLC Inputs 4 thru 7 are used to select the Modbus-RTU local unit address. The dryer is shipped with a wire supplying 24VDC to PLC IN-04. Use this wire, and additional jumper wires, to change the configuration according to the chart.

IN-04	IN-05	IN-06	IN-07	ADDRESS
24VDC	open	open	open	1 (default)
Open	24VDC	open	open	2
24VDC	24VDC	open	open	3
Open	open	24VDC	open	4
24VDC	open	24VDC	open	5
Open	24VDC	24VDC	open	6
24VDC	24VDC	24VDC	open	7
Open	open	open	24VDC	8
24VDC	open	open	24VDC	9
Open	24VDC	open	24VDC	10
24VDC	24VDC	open	24VDC	11
Open	open	24VDC	24VDC	12
24VDC	open	24VDC	24VDC	13
Open	24VDC	24VDC	24VDC	14
24VDC	24VDC	24VDC	24VDC	15

**Example #1** – To change from default address 1 to address 2, move the wire from IN-04 to IN-05

**Example #2** – To change from default address 1 to address 3, keep the wire at IN-04 and add a jumper between IN-04 and IN-05

**Example #3** –To change from default address 1 to address 6, move the wire from IN-04 to IN-05 and add a jumper from IN-05 to IN-06.

## 6.2 Modbus-TCP (Ethernet Port)

The standard controller is set to acquire its Ethernet IP settings from a DHCP server. For Static Ethernet IP settings, the user can use the micro SD Card slot to configure a static IP Address. Insert a Micro SD card with a ConfigMeFirst.Txt file into the SD Card slot on the right side of the PLC and recycle power. Refer to this Sample ConfigMeFirst.txt file for formatting the file with the IP address settings. The SD card must permanently remain in the card slot in order for the IP address settings to remain active.

Sample ConfigMeFirst.txt File

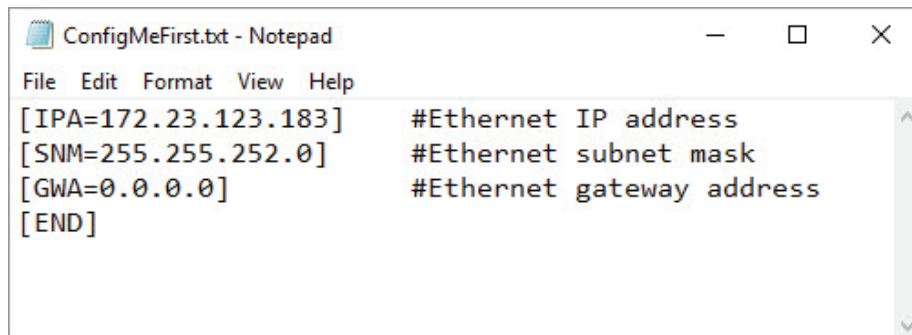

```

ConfigMeFirst.txt - Notepad
File Edit Format View Help
[IPA=172.23.123.183] #Ethernet IP address
[SNM=255.255.252.0] #Ethernet subnet mask
[GWA=0.0.0.0] #Ethernet gateway address
[END]
    
```

## 6.3 Modbus Register MAP

















ADDRESS	DESCRIPTION	TYPE	RANGE	DEFAULT
30001	Dewpoint Temperature (F)	R Integer	-148 to 68	-
30002	Switching Failure Alarm Register 0 – No Alarm 1 – Blowdown Left 2 – Blowdown Right 3 – Repressurization Left 4 – Repressurization Right 5 - Drying Left 6 – Drying Right	R Integer	0 to 6	-
40001	Variable Cycle Time Setpoint	R/W Integer	-60 to +20	-40F
40002	High Dewpoint Alarm Setpoint	R/W Integer	-50 to +50	-20F
00001	Alarm Reset	R/W Boolean	1	0
00002	Enable Variable Cycling	R/W Boolean	0 or 1	1
00003	Enable Dewpoint Alarm	R/W Boolean	0 or 1	1
00004	Enable Blowdown Alarm	R/W Boolean	0 or 1	1
00005	Enable Repressurization Alarm	R/W Boolean	0 or 1	1
10001	Alarm - High Dewpoint	R Boolean	0 or 1	-
10002	Alarm – Failure to Switch	R Boolean	0 or 1	-
10003	Alarm - Left Blowdown	R Boolean	0 or 1	-
10004	Alarm - Right Blowdown	R Boolean	0 or 1	-
10005	Alarm - Left Repressurization	R Boolean	0 or 1	-
10006	Alarm - Right Blowdown	R Boolean	0 or 1	-
10007	Alarm - Left Drying Pressure	R Boolean	0 or 1	-
10008	Alarm - Right Drying Pressure	R Boolean	0 or 1	-
10009	Status – Running	R Boolean	0 or 1	-
10010	Status – Repressurizing	R Boolean	0 or 1	-
10011	Status – Regenerating	R Boolean	0 or 1	-
10012	Status – Extended Drying	R Boolean	0 or 1	-

## 7.0 Servicing

**WARNING:** Only competent personnel trained, qualified, and approved by Parker should perform installation, commissioning, service and repair procedures. Use caution when near the dryer and wear eye protection. Hearing protection is recommended.

### 7.1 Service intervals

PPD Series Desiccant Compressed Air Dryers are equipped with an hour meter, which is activated when the system is running. The hour meter is to be used as a guide for sustaining service intervals. If service intervals are stated in both months & hours, the system should be serviced based on whichever comes first.

Component	Operation	Daily	Weekly	Monthly	6 months	12 months
Filter Drains	Check for proper drain operation					
Exhaust Mufflers	Verify there is no backpressure on regenerating tank. Clean or replace clogged exhaust mufflers as needed.					
Air Motor Silencer	Clean or replace clogged silencer as needed.					
Temperature Gauge	Check temperature to ensure air application is with dryer design spec. Verify proper working condition of lubricator if equipped.					
Lubricator	Check and fill as necessary (when installed and during operation).					
Complete Assembly	Check for air leaks (when installed and during operation).					
Pre/After Filters	Replace filter elements					
Y-Strainer	Remove straining screen and clean if equipped.					
Desiccant	Check desiccant quality. Replacement is recommended every 3-5 years.					
Control Air Filter	Replace filter element					
Switching Valves	Check condition. Rebuild and replace wear parts as needed.					
Check Valves	Check condition. Rebuild and replace wear parts as needed.					

 = Check       = Service



## 7.2 Spare Parts and Maintenance Kits List

	MODEL	PPD500	PPD1000	PPD1600	PPD3000
	P&ID DRAWING NUMBER	FS11800	FS11801	FS11798	FS11799
DESICCANT	PART ID	PART NUMBER	PART NUMBER	PART NUMBER	PART NUMBER
DESICCANT 25LB BAGS (QTY)		PDA-1/8-25 (24)	PDA-1/8-25 (48)	PDA-1/8-25 (80)	PDA-1/8-25 (144)
FILTER ELEMENTS AND AIR MOTOR OIL	PART ID	PART NUMBER	PART NUMBER	PART NUMBER	PART NUMBER
COARSE COALESCER ELEMENT (QTY)	PF1	P045AO (1)	P055AO (1)	JE-C10C0800 (1)	JE-C10C3001 (1)
FINE COALESCER ELEMENT (QTY)	PF2	P045AA (1)	P055AA (1)	P060AA (3)	JE-C3001 (1)
PARTICULATE ELEMENT (QTY)	AF1	P045AO (1)	P055AO (1)	JE-C10C0800 (1)	JE-C10C3001 (1)
CONTROL AIR FILTER ELEMENT (QTY)	CF1	TP2201-PE (1)	TP2201-PE (1)	TP2201-PE (1)	TP2201-PE (1)
AIR MOTOR OIL (1 GAL) *		GO41	GO41	GO41	N/A
REPAIR KITS	PART ID	PART NUMBER	PART NUMBER	PART NUMBER	PART NUMBER
INLET VALVE REPAIR KIT	PV2, PV3	N/A	TP7631-BD-HP-RK	TP7631-BD-HP-RK	TP7641-BD-HP-RK
INLET VALVE ACTUATOR	PV2, PV3	N/A	TP7631-BD-HP-A	TP7631-BD-HP-A	TP7631-BD-HP-A
EXHAUST VALVE REPAIR KIT	PV1, PV4	N/A	N/A	N/A	TP7631-BD-HP-RK
EXHAUST VALVE ACTUATOR	PV1, PV4	N/A	N/A	N/A	TP7532-B-HP-A
OUTLET CHK VALVE REPAIR KIT	CV1, CV2	N/A	TP7431-SWRK	TP7431-SWRK	TP7441-SWRK
PURGE CHK VALVE REPAIR KIT	CV3, CV4	N/A	N/A	N/A	TP7431-SWRK
MUFFLER REPLACEMENT CORES	ES1, ES2	N/A	TP4230-RK-1	TP4230-RK-1	TP4230-RK-1

Note:

\* Models with aftercooler option    \*\* Models with basic controller    \*\*\* Models with advanced controller option

### Maintenance Kits

Filter Element Replacement Kit	
Replacement elements for pre-filters, after-filter, control air filter and exhaust mufflers	MK-PPD0500-F
	MK-PPD1000-F
	MK-PPD1600-F
	MK-PPD3000-F

Valve Maintenance Kit	
Includes inlet, exhaust, and check valve repair kits	MK-PPD0500-V
	MK-PPD1000-V
	MK-PPD1600-V
	MK-PPD3000-V

## 7.2 Spare Parts and Maintenance Kits List (Continued)

	MODEL	PPD500	PPD1000	PPD1600	PPD3000
	P&ID DRAWING NUMBER	FS11800	FS11801	FS11798	FS11799
REPLACEMENT PARTS	PART ID	PART NUMBER	PART NUMBER	PART NUMBER	PART NUMBER
AFTERCOOLER AIR MOTOR *	AM1	AP500-TWR-M	AP1000-TWR-M	AP1600-TWR-M	N/A
AFTERCOOLER FAN *	ACF1	AP500-TWR-F	AP1000-TWR-F	AP1600-TWR-F	N/A
INLET VALVE ASSEMBLY	PV2, PV3	TP7620-KV	TP7631-BD-HP	TP7631-BD-HP	TP7641-BD-HP
EXHAUST VALVE ASSEMBLY	PV1, PV4	TP7515-KV	TP7520-KV	TP7520-KV	TP7532-B-HP
OUTLET CHECK VALVE	CV1, CV2	TP7420-KV	TP7431-SW	TP7431-SW	TP7441-SW
PURGE CHECK VALVE	CV3, CV4	TP7410-KV	TP7410-KV	TP7415-KV	TP7431-SW
CONTROL SOLENOID VALVE	S1, S2, S3, S4	P2LAX591ESHDDB53	P2LAX591ESHDDB53	P2LAX591ESHDDB53	P2LAX591ESHDDB53
EXHAUST MUFFLER	ES1, ES2	TP4215-1	TP4230-1	TP4230-1	TP4230-1
CONTROL AIR FILTER	CF1	TP2201-P	TP2201-P	TP2201-P	TP2201-P
SAFETY RELIEF VALVE	PSV1, PSV2	TP7110	TP7110	TP7115-165	TP7120-165
PRESSURE GAUGE	PI1, PI2, PI3, PI4	DP42100-L-SS	DP42100-L-SS	DP42100-L-SS	DP42100-L-SS
PREFILTER FLOAT DRAIN	FD1, FD2, FD3	TTD-TWR	TTD-TWR	TTD-TWR	TTD-TWR
PREFILTER SUMP DRAIN	FD4, FD5	N/A	N/A	N/A	505BC
COARSE COALESCER DP INDICATOR	DPI1	N/A	N/A	DPG-15	N/A
FINE COALESCER DP INDICATOR	DPI2	N/A	N/A	DPM-060	N/A
PARTICULATE DP INDICATOR	DPI3	N/A	N/A	DPG-15	N/A
AIR MOTOR FILTER/SILENCER *	ES3	MIST-X25	MIST-X50	MIST-X150	N/A
AIR MOTOR REGULATOR *	PR3	TP4605-R	TP4610-R	TP4610-R	N/A
MIST LUBRICATOR *	ML1	L606-08G	L606-08G	L606-08G	N/A
AIR MOTOR RELIEF VALVE *	PSV4	TP7102-110	TP7102-110	TP7102-110	N/A
PLC **	PLC1	TP2656-PPD	TP2656-PPD	TP2656-PPD	TP2656-PPD
MOISTURE INDICATOR **	MI1	F009-033-AF	F009-033-AF	F009-033-AF	F009-033-AF
FUSE, 2A	F1	EF0200-G	EF0200-G	EF0200-G	EF0200-G
PRESSURE SWITCH	PS1	TP2320	TP2320	TP2320	TP2320
FUSE, 125mA ***	F2	EF0012-1-FA	EF0012-1-FA	EF0012-1-FA	EF0012-1-FA
PLC ***, ****	PLC1	TP2657-PPD ****	TP2657-PPD ****	TP2657-PPD ****	TP2657-PPD ****
DEWPOINT PROBE ***	AE1	TP2190-1-UL	TP2190-1-UL	TP2190-1-UL	TP2190-1-UL
HOUR METER	HM1	TP9002	TP9002	TP9002	TP9002
VALVE CABLE		TP8004-C5LS	TP8004-C5LS	TP8004-C5LS	TP8004-C5LS
PANEL METER ***	DPM	TP2192-6	TP2192-6	TP2192-6	TP2192-6
OVERLAY - BASIC***		TP2656-LBL1	TP2656-LBL1	TP2656-LBL1	TP2656-LBL1
OVERLAY - ADVANCED***		TP2657-LBL1	TP2657-LBL1	TP2657-LBL1	TP2657-LBL1
POWER SUPPLY ***	PS	TP2500-PS-24LP	TP2500-PS-24LP	TP2500-PS-24LP	TP2500-PS-24LP
RELAY **	CR1	TP2581-S-120VAC	TP2581-S-120VAC	TP2581-S-120VAC	TP2581-S-120VAC

Note:

\* Models with aftercooler option    \*\* Models with basic controller    \*\*\* Models with advanced controller option



Page intentionally left blank

## 8.0 Troubleshooting

	SYMPTOM								
	Dryer not switching	Excessive air loss on regenerating tower	Back pressure in regenerating tower	Moisture downstream of dryer	Aftercooler fan not operating	Aftercooler fan runs slow	Oil mist present at air motor exhaust	No lights on	
<b>POSSIBLE CAUSE</b>									
High ambient air temperature				X					
High inlet air temperature				X					
Failed control solenoid valve	X	X		X					
Failed pressure switch	X			X					
Element dirty				X					
Element collapsed				X					
Desiccant worn				X					
Desiccant contaminated			X	X					
Leaking exhaust valve	X								
Leaking inlet valve		X	X						
Leaking check valve		X	X						
No power	X			X				X	
Blown control fuse	X			X				X	
No output from controller	X	X		X					
Controller inoperative	X			X				X	
Air pressure too low	X			X					
Control air valve closed	X			X					
Inlet air flow exceeds dryer capacity				X					
Purge/repress air rate too low				X					
Purge/repress air rate too high		X	X						
Moist air mixing from another source mixing downstream of dryer				X					
Drain valve closed				X					
Drain plugged				X					
Exhaust muffler clogged			X	X					
Restricted cooling air flow				X		X			
Dirt, moisture, rust present in air motor				X	X	X			
Air motor valve is closed				X	X				
Low air pressure to air motor				X		X			
Restricted air motor exhaust				X	X	X			
Air motor is ceased				X	X				
Oil mist setting too high							X		

	Excessive pressure drop	Failure to switch alarm	
			<b>TEST REMEDY</b>
			Move dryer to cooler area and away from direct sunlight.
			Check discharge air temp of compressor and verify compressor is operating correctly. Check condition of dryer aftercooler for proper operation if equipped.
	X	X	Verify valve DIN cable light is illuminated at correct time during dryer operation sequence. If valve doesn't open when cable is lit, rebuild or replace valve. If cable does not light, check continuity of cable and controller output to identify failure mode.
		X	Use gauges and plc to verify switch states. Verify both towers exceed 65 psig before the end of repressurization. If so, check continuity across each pressure switch and replace failed component.
	X		Check filter element condition and clean or replace.
	X		Check filter element condition and replace.
			High dewpoint and excessive desiccant dusting in after-filter element and exhaust mufflers signal worn, broken down desiccant. Replace desiccant..
	X		Desiccant contaminated with oil must be replaced. Check condition of pre-filter elements and drains as well as compressor for proper operation.
	X	X	Check for air leaks at exhaust valve muffler of valve that should be closed. If present, rebuild or replace valve.
	X		Check for higher than usual air loss through open exhaust valve during regeneration to detect air loss from a leaking inlet valve. Rebuild or replace valve.
			Higher than usual air loss during regeneration or back pressure in regenerating tower can result from a leaking check valve. Rebuild or replace valve.
			Verify dryer is plugged into correct power supply. Check power source is ready and available.
			Pull fuse and check condition. Replace as needed.
		X	Check continuity of output suspected of failure. Replace controller as needed.
		X	Replace controller as needed.
	X	X	Verify air pressure into dryer is with dryer design specifications.
		X	If closed, open control air valve to allow switching of actuated valves.
	X		Verify inlet air flow rate to dryer is within dryer design specifications.
		X	Check setting on purge pressure gauge during regeneration and adjust to specification as needed.
	X		Check setting on purge pressure gauge during regeneration and adjust to specification as needed.
			Check dewpoint of air exiting dryer, before mixing with downstream air to verify correct dryer operation. Correct downstream issues as needed.
			Open drain valve if it is closed to allow proper drain function.
			Close drain valve at inlet of drain. Disconnect drain tubing and check for blockages. Rebuild or replace drain as needed.
			Check for backpressure in regenerating tower. With double hearing protection, remove exhaust muffler. If back pressure drops to 0 psig, clean or replace exhaust muffler.
			Check for obstruction or blockage at aftercooler fins and remove restriction.
			Disassemble air motor. Clean and rebuild. Ensure dryer is operating correctly and delivering dry, clean air to air motor.
			Open air motor valve to start air motor.
			Check setting on air motor regulator gauge and adjust to specifications.
			Check condition of air motor muffler. Clean or replace.
			Replace air motor. Ensure clean, dry air is delivered to air motor and oil lubricator has oil.
			Adjust oil lubricator mist setting to specifications.

### 9.0 Flow Schematics

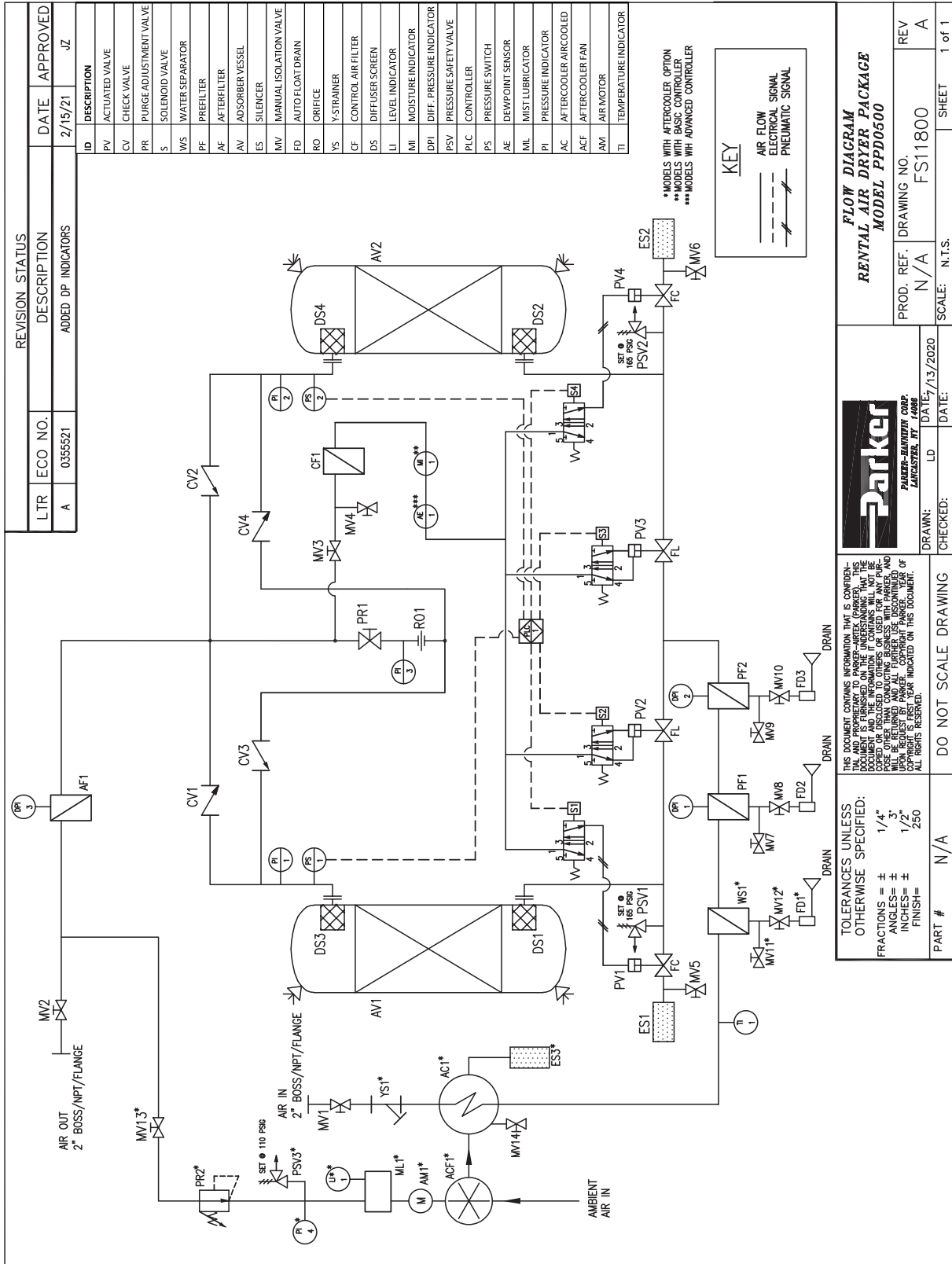

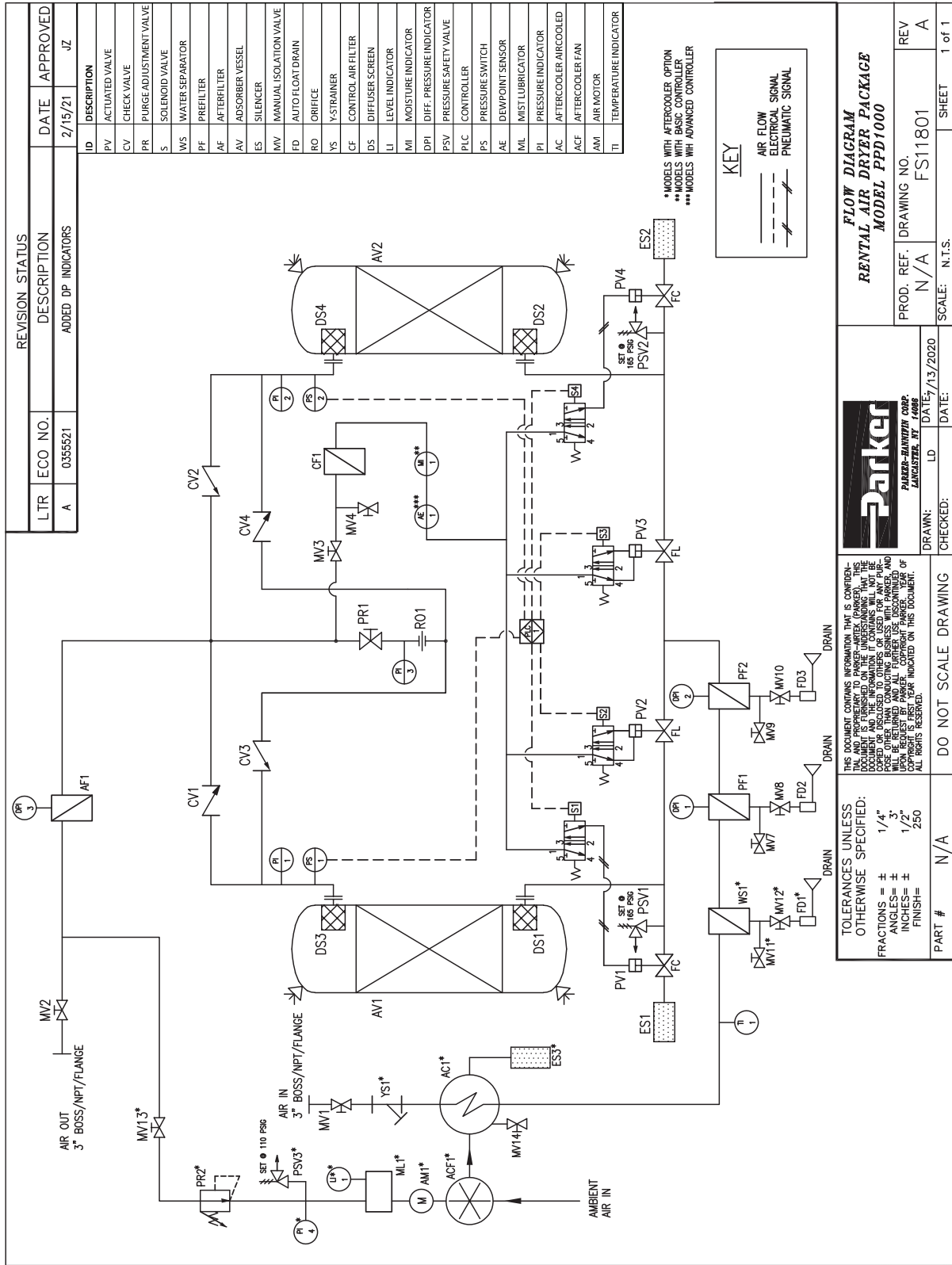

**FLOW DIAGRAM**  
**RENTAL AIR DRYER PACKAGE**  
**MODEL PPD1000**



THIS DOCUMENT CONTAINS INFORMATION THAT IS CONFIDENTIAL AND THE INFORMATION CONTAINED HEREIN IS THE PROPERTY OF PARKER. IT IS TO BE USED ONLY FOR THE PURPOSES SPECIFIED IN THIS DOCUMENT. ALL RIGHTS RESERVED.

**TOLERANCES UNLESS OTHERWISE SPECIFIED:**

FRACTIONS = ± 1/4"  
 ANGLES = ± 3°  
 DIMENSIONS = ± 1/2"  
 FINISH = 250

**DO NOT SCALE DRAWING**

PART # N/A

PROD. REF. DRAWING NO. FS11801  
 REV A

DRAWN: DATE: 7/13/2020  
 CHECKED: N.T.S.

SCALE: N.T.S.

SHEET 1 of 1



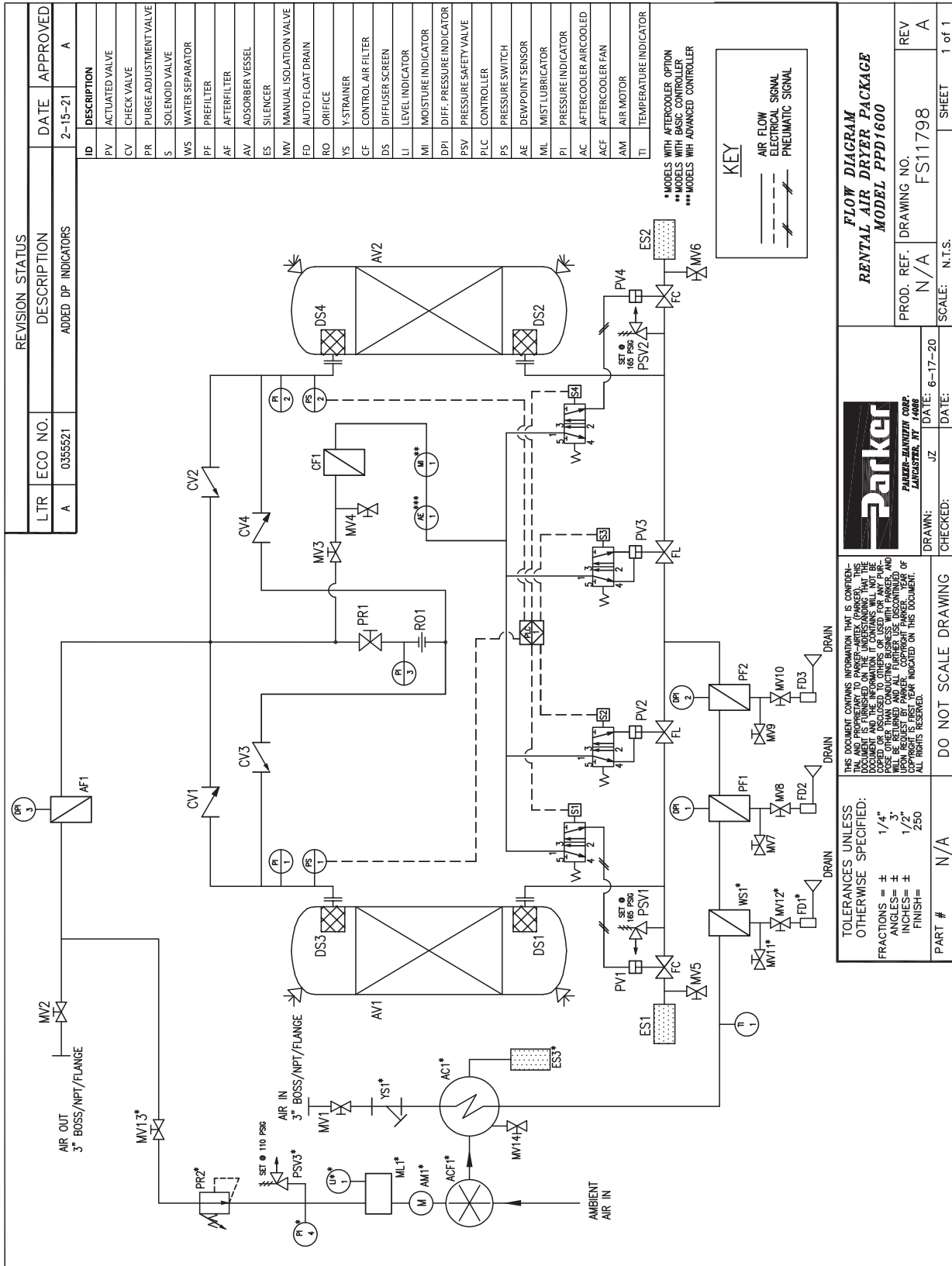

**FLOW DIAGRAM  
RENTAL AIR DRYER PACKAGE  
MODEL PPD1600**

THIS DOCUMENT CONTAINS INFORMATION THAT IS CONFIDENTIAL AND PROPRIETARY TO PARKER-HANNIFIN CORP. IT IS TO BE KEPT SECRET AND NOT DISCLOSED TO OTHERS. ANY REPRODUCTION, COPIED OR DISCLOSED TO OTHERS OR USED FOR ANY PURPOSE WITHOUT THE WRITTEN PERMISSION OF PARKER-HANNIFIN CORP. WILL BE RETAINED AND ALL FURTHER USE DISCONTINUED UPON REQUEST BY PARKER-HANNIFIN CORP. ONE YEAR OF ALL RIGHTS RESERVED.

TOLERANCES UNLESS OTHERWISE SPECIFIED:  
 FRACTIONS = ± 1/4"  
 ANGLES = ± 3°  
 INCHES = ± 1/2"  
 FINISH = 250

PROD. REF.	N/A	DRAWING NO.	FS11798	REV	A
CHECKED:	N.T.S.	SCALE:		SHEET	1 of 1

DRAWN:	JZ	DATE:	6-17-20
--------	----	-------	---------





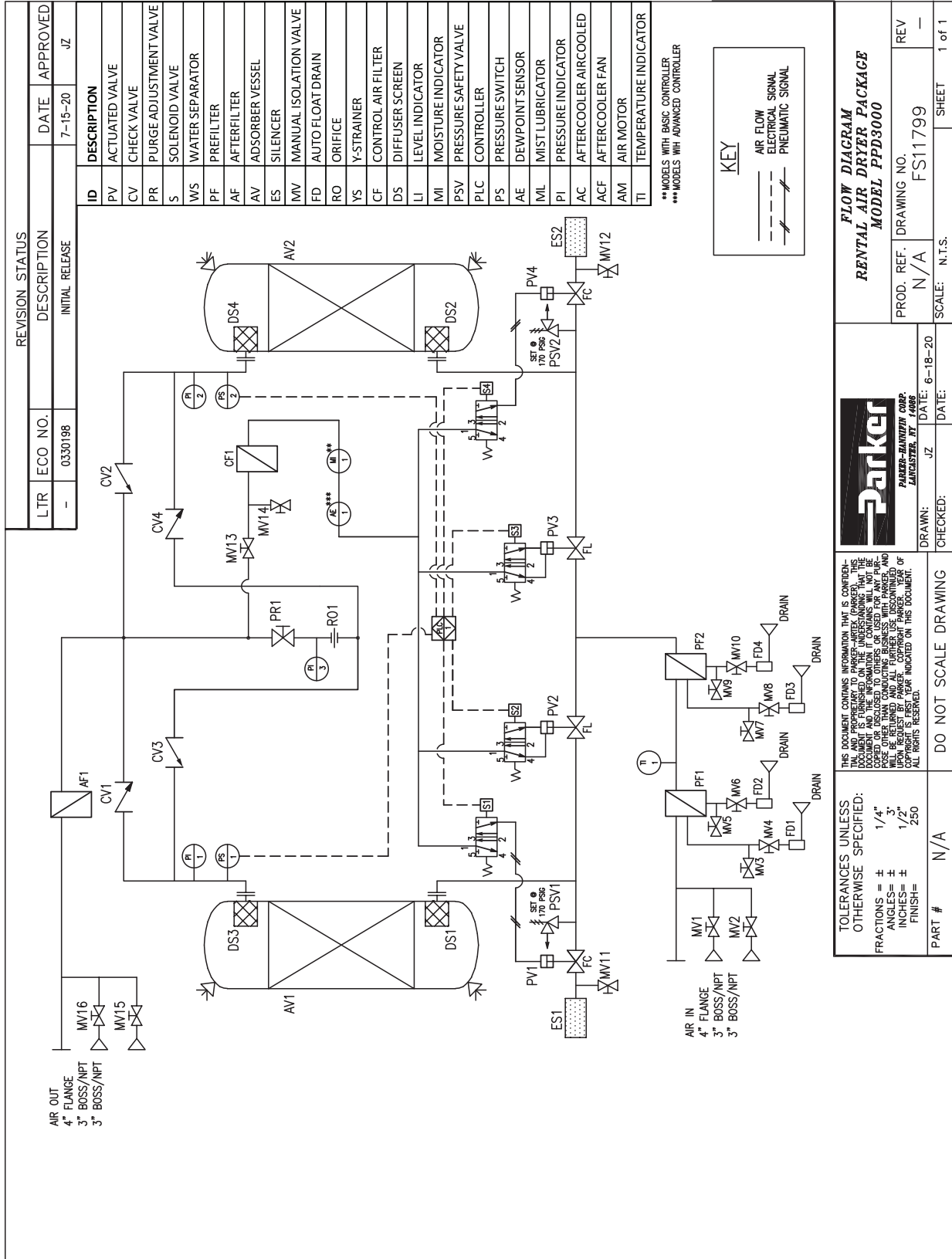

**Parker**  
PARKER-HANZLIN CORP.  
LANCASTER, NY 14098

**FLOW DIAGRAM**  
**RENTAL AIR DRYER PACKAGE**  
**MODEL PPD3000**

PROD. REF. N/A

DRAWING NO. FS11799

REV. —

SCALE: N.T.S.

SHEET 1 of 1

DATE: 6-18-20

DATE: 6-18-20

CHECKED: JZ

DRAWN: N/A

DO NOT SCALE DRAWING

PART # N/A

TOLERANCES UNLESS OTHERWISE SPECIFIED:

FRACTIONS = ± 1/4"

ANGLES = ± 3°

INCHES = ± 1/2"

FINISH = 250

THIS DOCUMENT CONTAINS INFORMATION THAT IS CONFIDENTIAL AND PROPRIETARY TO PARKER-HANZLIN CORP. THIS DOCUMENT IS FURNISHED ON THE UNDERSTANDING THAT THE USER WILL NOT REPRODUCE, COPY, OR DISCLOSE TO OTHERS OR USE FOR ANY PURPOSE OTHER THAN THAT AUTHORIZED BY PARKER-HANZLIN CORP. WITHOUT THE WRITTEN PERMISSION OF PARKER-HANZLIN CORP. IN THE EVENT OF SUCH VIOLATION, PARKER-HANZLIN CORP. WILL BE ENTITLED TO TAKE LEGAL ACTION TO ENFORCE ITS PATENT AND TRADE SECRET RIGHTS AND TO RECOVER ALL DAMAGES AND COSTS INCURRED. ALL RIGHTS RESERVED.

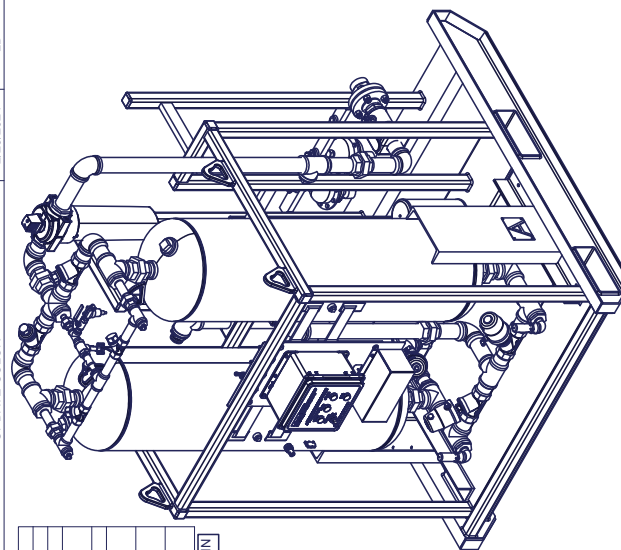
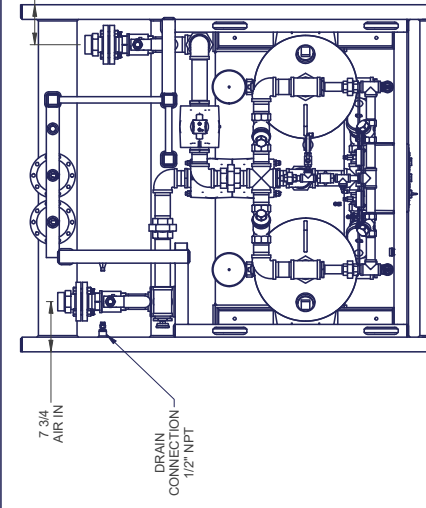
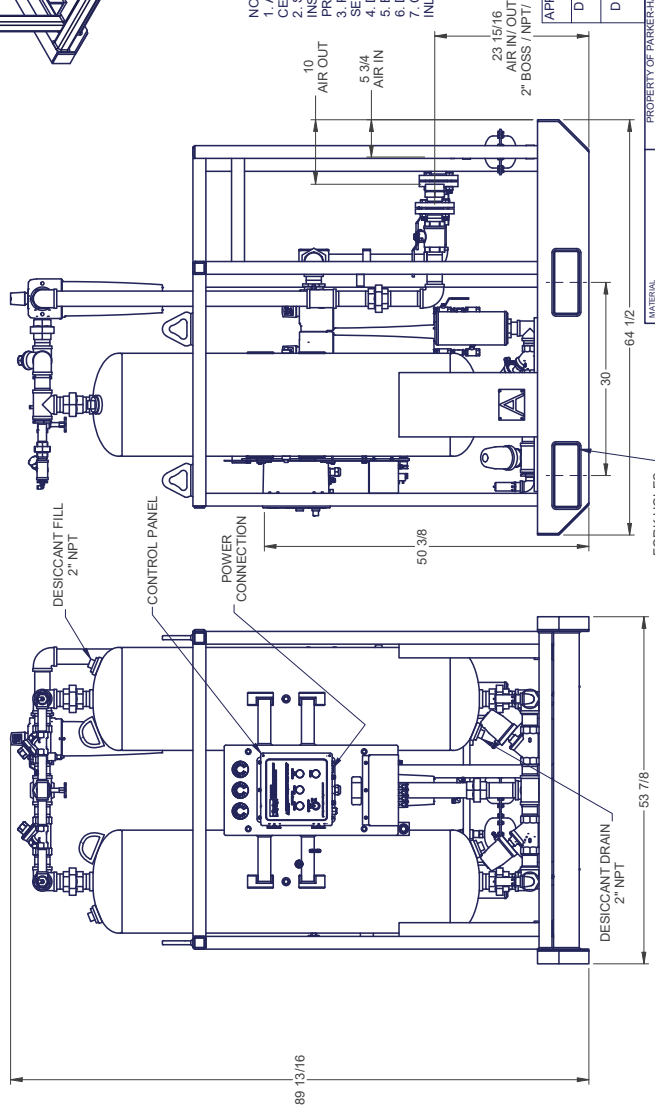

# 10.0 General Arrangement Drawings

ECO NO. 0355088	REVISION HISTORY DESCRIPTION UPDATE COLOR DATE 2/23/2021 APPROVED LD																																				
<table border="1" style="width: 100%; border-collapse: collapse;"> <tr> <td colspan="2" style="text-align: center;">PPD0500BN</td> </tr> <tr> <td>MAX PSI</td> <td>150 PSIG</td> </tr> <tr> <td>MIN PSI</td> <td>80 PSIG</td> </tr> <tr> <td>CAPACITY</td> <td>500 CFM</td> </tr> <tr> <td>INLET AIR TEMP</td> <td>100°F</td> </tr> <tr> <td>OUTLET AIR TEMP</td> <td>150°F</td> </tr> <tr> <td>AMBIENT AIR TEMP</td> <td>40°F</td> </tr> <tr> <td>AMBIENT AIR MAX TEMP</td> <td>120°F</td> </tr> <tr> <td>MOTOR HP</td> <td>120</td> </tr> <tr> <td>MOTOR FLA</td> <td>0</td> </tr> <tr> <td>HEATER AMPACITY</td> <td>50/60</td> </tr> <tr> <td>DRYER FLA</td> <td>2.0</td> </tr> <tr> <td>MIN CIRCUIT AMPACITY</td> <td>N/A</td> </tr> <tr> <td>MAX FUSE</td> <td>N/A</td> </tr> <tr> <td>SCCR</td> <td>N/A</td> </tr> <tr> <td colspan="2" style="text-align: center;">MIN SPACING TO COMBUSTIBLE SURFACE <input type="checkbox"/></td> </tr> <tr> <td colspan="2" style="text-align: center;">EQUIPMENT SUITABLE FOR OUTDOOR USE ONLY IF CHECKED <input checked="" type="checkbox"/></td> </tr> </table>		PPD0500BN		MAX PSI	150 PSIG	MIN PSI	80 PSIG	CAPACITY	500 CFM	INLET AIR TEMP	100°F	OUTLET AIR TEMP	150°F	AMBIENT AIR TEMP	40°F	AMBIENT AIR MAX TEMP	120°F	MOTOR HP	120	MOTOR FLA	0	HEATER AMPACITY	50/60	DRYER FLA	2.0	MIN CIRCUIT AMPACITY	N/A	MAX FUSE	N/A	SCCR	N/A	MIN SPACING TO COMBUSTIBLE SURFACE <input type="checkbox"/>		EQUIPMENT SUITABLE FOR OUTDOOR USE ONLY IF CHECKED <input checked="" type="checkbox"/>		<p><b>NOTES:</b></p> <ol style="list-style-type: none"> <li>ALL DIMENSIONS ARE APPROXIMATE AND SUBJECT TO CHANGE UNLESS CERTIFIED</li> <li>SEE MANUAL FOR COMPLETE SPECIFICATIONS, CAPACITIES, INSTALLATION, OPERATION &amp; MAINTENANCE INSTRUCTIONS, &amp; SAFETY PRECAUTIONS</li> <li>MINIMUM 4" ON EACH SIDE OF DRYER AND OVERHEAD FOR SERVICE AND MAINTENANCE</li> <li>DO NOT OPERATE WITHOUT PROPER PURGE FLOW</li> <li>BYPASS VALVES MUST BE BUBBLE TIGHT</li> <li>DO NOT SURGE DESICCANT BED OR FILTERS</li> <li>CAPACITY AND SIZING BASED ON CAGI STANDARD, 100°F INLET, 100 PSI INLET, 68° AMBIENT</li> </ol>	
PPD0500BN																																					
MAX PSI	150 PSIG																																				
MIN PSI	80 PSIG																																				
CAPACITY	500 CFM																																				
INLET AIR TEMP	100°F																																				
OUTLET AIR TEMP	150°F																																				
AMBIENT AIR TEMP	40°F																																				
AMBIENT AIR MAX TEMP	120°F																																				
MOTOR HP	120																																				
MOTOR FLA	0																																				
HEATER AMPACITY	50/60																																				
DRYER FLA	2.0																																				
MIN CIRCUIT AMPACITY	N/A																																				
MAX FUSE	N/A																																				
SCCR	N/A																																				
MIN SPACING TO COMBUSTIBLE SURFACE <input type="checkbox"/>																																					
EQUIPMENT SUITABLE FOR OUTDOOR USE ONLY IF CHECKED <input checked="" type="checkbox"/>																																					
<table border="1" style="width: 100%; border-collapse: collapse;"> <tr> <td>APPROXIMATE WEIGHT</td> <td>2125 LB</td> <td>NEMA RATING</td> <td>4</td> <td>PURGE FLOW</td> <td>75 CFM</td> </tr> <tr> <td>DESICCANT AMOUNT</td> <td>600 LB</td> <td>CONTROLS</td> <td>BASIC</td> <td>PURGE SET PRESSURE</td> <td>42 PSIG</td> </tr> <tr> <td>DESICCANT FILLED</td> <td>YES</td> <td>CONTROL TUBING</td> <td>NYLON</td> <td>PAINT</td> <td>AGATE GREY</td> </tr> </table>		APPROXIMATE WEIGHT	2125 LB	NEMA RATING	4	PURGE FLOW	75 CFM	DESICCANT AMOUNT	600 LB	CONTROLS	BASIC	PURGE SET PRESSURE	42 PSIG	DESICCANT FILLED	YES	CONTROL TUBING	NYLON	PAINT	AGATE GREY	<p>PROPERTY OF PARKER HANNIFIN CORPORATION                  THIS DOCUMENT AND ITS CONTENTS ARE THE PROPERTY OF PARKER HANNIFIN CORPORATION AND IS LOANED TO THE USER UNDER THE UNDERSTANDING THAT THE USER WILL NOT REPRODUCE OR TRANSMIT IN ANY FORM OR BY ANY MEANS, ELECTRONIC OR MECHANICAL, INCLUDING PHOTOCOPYING, RECORDING, OR BY ANY INFORMATION STORAGE AND RETRIEVAL SYSTEM, WITHOUT THE WRITTEN PERMISSION OF PARKER HANNIFIN CORPORATION. ALL RIGHTS RESERVED.                  USE CORRESPONDING TOLERANCES UNLESS OTHERWISE SPECIFIED</p>																	
APPROXIMATE WEIGHT	2125 LB	NEMA RATING	4	PURGE FLOW	75 CFM																																
DESICCANT AMOUNT	600 LB	CONTROLS	BASIC	PURGE SET PRESSURE	42 PSIG																																
DESICCANT FILLED	YES	CONTROL TUBING	NYLON	PAINT	AGATE GREY																																
																																					
JOB NUMBER: PPD0500BN REVIEWED BY: _____ DATE: _____		SHEET METAL PARTS ALL TOLERANCES: ± .005 SPACING: ± .005 ANGLES: ± 3° SURFACE FINISH: A																																			

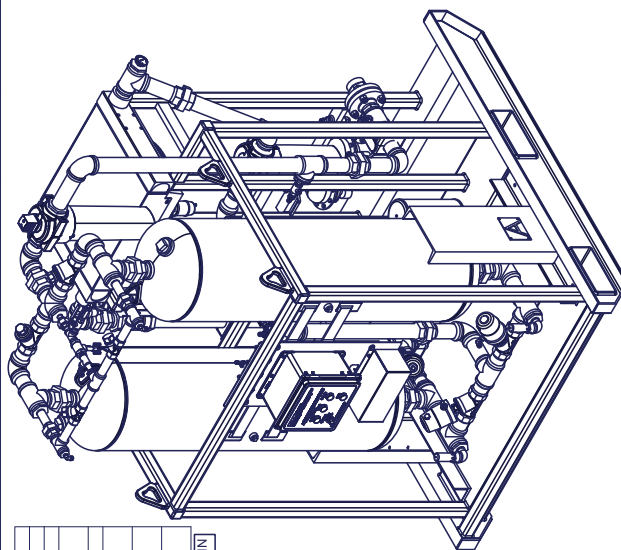
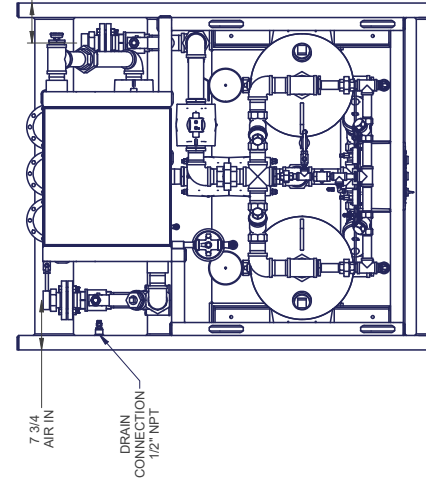
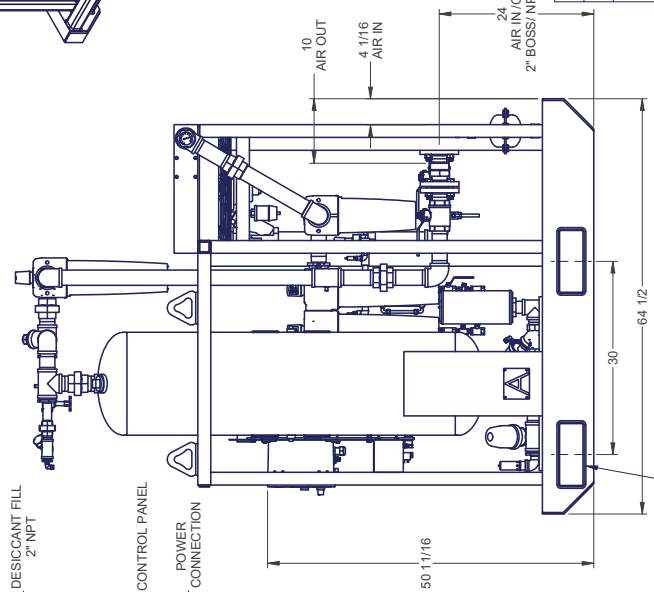

<p>ECO NO. 0355088</p> <p>REVISION HISTORY</p> <p>DESCRIPTION UPDATED PAINT COLOR</p> <p>DATE 2/23/2021</p> <p>APPROVED LD</p>		<table border="1" style="width: 100%; border-collapse: collapse;"> <tr> <td colspan="2">PPD0500BA</td> </tr> <tr> <td>MAX PSI</td> <td>150 PSIG</td> </tr> <tr> <td>MIN PSI</td> <td>80 PSIG</td> </tr> <tr> <td>CAPACITY</td> <td>500 CFM</td> </tr> <tr> <td>INLET AIR TEMP</td> <td>100°F</td> </tr> <tr> <td>OUTLET AIR TEMP</td> <td>150°F</td> </tr> <tr> <td>AMBIENT AIR MIN TEMP</td> <td>40°F</td> </tr> <tr> <td>AMBIENT AIR MAX TEMP</td> <td>105°F</td> </tr> <tr> <td colspan="2">EQUIPMENT SUITABLE FOR OUTDOOR USE ONLY IF CHECKED <input checked="" type="checkbox"/> SURFACE</td> </tr> <tr> <td>MOTOR HP</td> <td>120</td> </tr> <tr> <td>MOTOR FLA</td> <td>0</td> </tr> <tr> <td>HEATER AMPACITY</td> <td>50/60</td> </tr> <tr> <td>DRYER FLA</td> <td>2.0</td> </tr> <tr> <td>MIN CIRCUIT AMPACITY</td> <td>N/A</td> </tr> <tr> <td>MAX FUSE</td> <td>N/A</td> </tr> <tr> <td>SCCR</td> <td>N/A</td> </tr> <tr> <td colspan="2">MIN SPACING TO COMBUSTIBLE SURFACE</td> </tr> </table>	PPD0500BA		MAX PSI	150 PSIG	MIN PSI	80 PSIG	CAPACITY	500 CFM	INLET AIR TEMP	100°F	OUTLET AIR TEMP	150°F	AMBIENT AIR MIN TEMP	40°F	AMBIENT AIR MAX TEMP	105°F	EQUIPMENT SUITABLE FOR OUTDOOR USE ONLY IF CHECKED <input checked="" type="checkbox"/> SURFACE		MOTOR HP	120	MOTOR FLA	0	HEATER AMPACITY	50/60	DRYER FLA	2.0	MIN CIRCUIT AMPACITY	N/A	MAX FUSE	N/A	SCCR	N/A	MIN SPACING TO COMBUSTIBLE SURFACE		<p><b>NOTES:</b></p> <ol style="list-style-type: none"> <li>ALL DIMENSIONS ARE APPROXIMATE AND SUBJECT TO CHANGE UNLESS CERTIFIED FOR COMPLETE SPECIFICATIONS, CAPACITIES, INSTANTANEOUS OPERATION &amp; MAINTENANCE INSTRUCTIONS, &amp; SAFETY PRECAUTIONS.</li> <li>PROVIDE MINIMUM 4" ON EACH SIDE OF DRYER AND OVERHEAD FOR SERVICE AND MAINTENANCE.</li> <li>DO NOT OPERATE WITHOUT PROPER PURGE FLOW.</li> <li>BYPASS VALVES MUST BE BUBBLE TIGHT.</li> <li>DO NOT SURGE DESICCANT BED OR FILTERS.</li> <li>CAPACITY AND SIZING BASED ON CAGI STANDARD, 100°F INLET, 100 PSI INLET, 68° AMBIENT.</li> <li>AFTER-COOLER AIR MOTOR SET PRESSURE: 40 PSIG.</li> <li>AIR MOTOR AIR CONSUMPTION: 25 CFM.</li> <li>AIR MOTOR LUBRICATOR RATE: 1 DROP PER MINUTE.</li> </ol>
PPD0500BA																																					
MAX PSI	150 PSIG																																				
MIN PSI	80 PSIG																																				
CAPACITY	500 CFM																																				
INLET AIR TEMP	100°F																																				
OUTLET AIR TEMP	150°F																																				
AMBIENT AIR MIN TEMP	40°F																																				
AMBIENT AIR MAX TEMP	105°F																																				
EQUIPMENT SUITABLE FOR OUTDOOR USE ONLY IF CHECKED <input checked="" type="checkbox"/> SURFACE																																					
MOTOR HP	120																																				
MOTOR FLA	0																																				
HEATER AMPACITY	50/60																																				
DRYER FLA	2.0																																				
MIN CIRCUIT AMPACITY	N/A																																				
MAX FUSE	N/A																																				
SCCR	N/A																																				
MIN SPACING TO COMBUSTIBLE SURFACE																																					
		<table border="1" style="width: 100%; border-collapse: collapse;"> <tr> <td>APPROXIMATE WEIGHT</td> <td>2325 LB</td> <td>NEMA RATING</td> <td>4</td> <td>PURGE FLOW</td> <td>75 CFM</td> </tr> <tr> <td>DESICCANT AMOUNT</td> <td>600 LB</td> <td>CONTROLS</td> <td>BASIC</td> <td>PURGE SET PRESSURE</td> <td>42 PSIG</td> </tr> <tr> <td>DESICCANT FILLED</td> <td>YES</td> <td>CONTROL TUBING</td> <td>NYLON</td> <td>RENTAL PAINT</td> <td>AGATE GREY</td> </tr> </table>	APPROXIMATE WEIGHT	2325 LB	NEMA RATING	4	PURGE FLOW	75 CFM	DESICCANT AMOUNT	600 LB	CONTROLS	BASIC	PURGE SET PRESSURE	42 PSIG	DESICCANT FILLED	YES	CONTROL TUBING	NYLON	RENTAL PAINT	AGATE GREY																	
APPROXIMATE WEIGHT	2325 LB	NEMA RATING	4	PURGE FLOW	75 CFM																																
DESICCANT AMOUNT	600 LB	CONTROLS	BASIC	PURGE SET PRESSURE	42 PSIG																																
DESICCANT FILLED	YES	CONTROL TUBING	NYLON	RENTAL PAINT	AGATE GREY																																
<p>JOB NUMBER: _____ DATE: _____</p> <p>REVIEWED BY: _____</p>		<p>MATERIAL: PPD0500BA</p> <p>PROPERTY OF PARKER HANNIFIN CORPORATION THIS DOCUMENT CONTAINS INFORMATION THAT IS UNCLASSIFIED AND CONTROLLED ONLY IN AS MUCH AS IT RELATES TO THE PROTECTION OF TRADE SECRETS, PROPRIETARY INFORMATION, AND/OR PATENT RIGHTS. IT IS THE POLICY OF PARKER HANNIFIN CORPORATION TO MAKE ALL INFORMATION CONTAINED HEREIN AVAILABLE TO THE PUBLIC. IT IS THE POLICY OF PARKER HANNIFIN CORPORATION TO MAKE ALL INFORMATION CONTAINED HEREIN AVAILABLE TO THE PUBLIC.</p> <p>USE CORRESPONDING TOLERANCES UNLESS OTHERWISE SPECIFIED.</p> <p>MACHINED PARTS: ALL TOLERANCES ± .004 INCHES ± .01</p> <p>SALES DRAWINGS: ALL TOLERANCES ± .004 INCHES ± .01</p> <p>FRACIONS: 3/16 INCHES ± .01</p> <p>FINISH: A SURFACE FINISH</p> <p>DRIVING NUMBER: PPD0500BA</p> <p>REVISION: A</p>																																			



ECONO.		REVISION HISTORY	
NO.	DESCRIPTION	DATE	APPROVED
0355091	UPDATED PAINT COLOR & FRAME	2/02/2021	LD

PPD1000BN		PPD1000BN	
MAX PSI	150 PSIG	VOLT	120
MIN PSI	100 PSIG	PHASE	1
CAPACITY	1000 CFM	MOTOR HP	N/A
INLET AIR MAX TEMP	120 °F	MOTOR FLA	N/A
OUTLET AIR MAX TEMP	150 °F	HEATER AMPCITY	N/A
AMBIENT AIR MIN TEMP	40 °F	DRYER FLA	3
AMBIENT AIR MAX TEMP	120 °F	MIN CIRCUIT AMPCITY	N/A
		MAX FUSE	N/A
		SCCR	N/A

USE ONLY IF CHECKED  MIN. SPACING TO COMBUSTIBLE SURFACE

**NOTES:**

1. ALL DIMENSIONS ARE APPROXIMATE AND SUBJECT TO CHANGE UNLESS CERTIFIED.
2. SEE MANUAL FOR COMPLETE SPECIFICATIONS, CAPACITIES, INSTALLATION, OPERATION & MAINTENANCE INSTRUCTIONS, & SAFETY PRECAUTIONS.
3. PROVIDE MINIMUM 4" ON EACH SIDE OF DRYER AND OVERHEAD FOR SERVICE AND MAINTENANCE.
4. DO NOT OPERATE WITHOUT PROPER PURGE FLOW.
5. BYPASS VALVES MUST BE BUBBLE TIGHT.
6. DO NOT SURGE DESICCANT BED OR FILTERS.
7. CAPACITY AND SIZING BASED ON CAGI STANDARD, 100 °F INLET, 100 PSI INLET, 68 °F AMBIENT.

APPROXIMATE WEIGHT	NEMA RATING	PURGE FLOW
3450 LB.	4	150 CFM
DESICCANT AMOUNT	CONTROLS	PURGE SET PRESSURE
1200 LB.	BASIC	49 PSIG
DESICCANT FILLED	TUBING	RENTAL
YES	NYLON	LAGATE GRAY

PROPERTY OF PARKER HANIFIN CORPORATION  
 THIS DRAWING AND ITS DIMENSIONS ARE THE PROPERTY OF PARKER HANIFIN CORPORATION AND IS LOANED TO YOU FOR YOUR INFORMATION ONLY. IT IS NOT TO BE REPRODUCED OR TRANSMITTED IN ANY FORM OR BY ANY MEANS, ELECTRONIC OR MECHANICAL, INCLUDING PHOTOCOPYING, RECORDING, OR BY ANY INFORMATION STORAGE AND RETRIEVAL SYSTEM. ALL RIGHTS RESERVED. COPYRIGHT © 2020 PARKER HANIFIN CORPORATION. ALL RIGHTS RESERVED.

WELDED PARTS AND MACHINED PARTS  
 ALL DIMENSIONS IN INCHES UNLESS OTHERWISE SPECIFIED  
 FRACTIONS ± 1/64  
 DECIMALS ± 0.005  
 ANGLES ± 30'

WELDED PARTS AND MACHINED PARTS  
 ALL DIMENSIONS IN INCHES UNLESS OTHERWISE SPECIFIED  
 FRACTIONS ± 1/64  
 DECIMALS ± 0.005  
 ANGLES ± 30'

JOB NUMBER: \_\_\_\_\_ DATE: \_\_\_\_\_  
 REVIEWED BY: \_\_\_\_\_





ECO NO.	DESCRIPTION	DATE	APPROVED
0355520	CHANGE PAINT COLOR	2/28/21	JZ

PPD1600BN		VOLT	120	MOTOR HP	N/A
MAX PSI	150 PSIG	PHASE	1	MOTOR FLA	N/A
MIN PSI	100 PSIG	HZ	50/60	HEATER	N/A
CAPACITY	1600 CFM			DRYER FLA	2
INLET AIR	120 °F			MIN CIRCUIT	N/A
OUTLET AIR	150 °F			AMPACITY	N/A
AMBIENT AIR	40 °F			MAX FUSE	N/A
AMBIENT AIR	120 °F			SCCR	N/A
MAX TEMP					

EQUIPMENT SUITABLE FOR OUTDOOR  MIN SPACING TO COMBUSTIBLE SURFACE

USE ONLY IF CHECKED

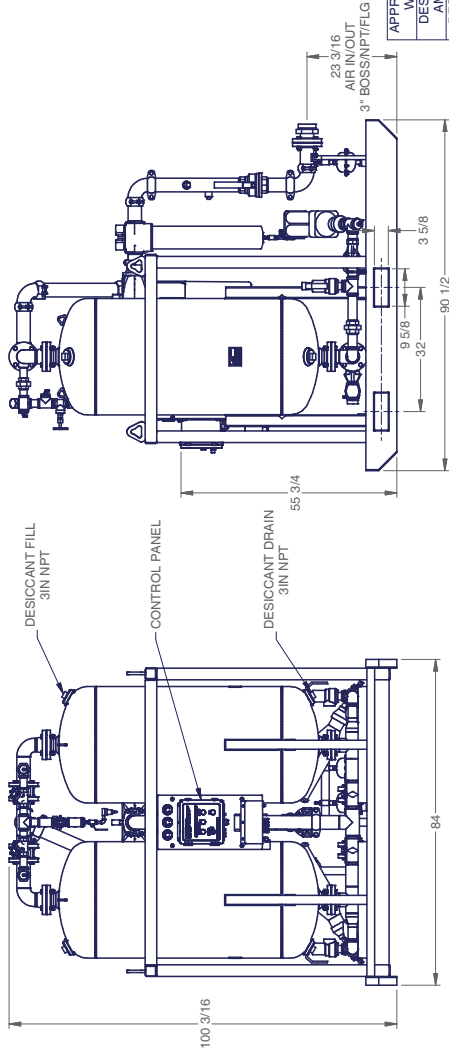
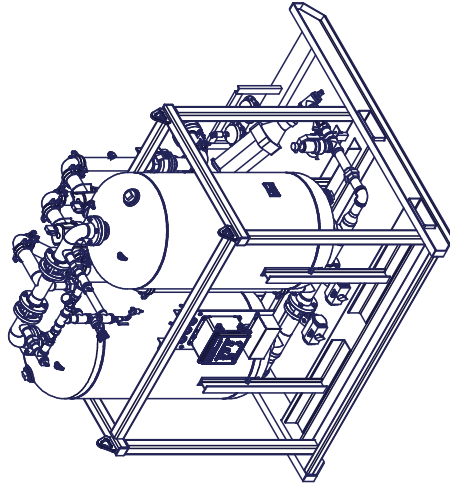
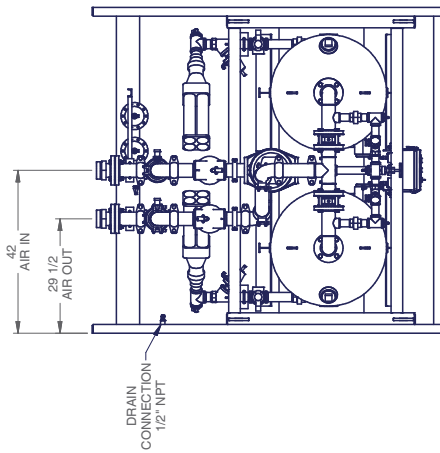

- NOTES:
1. ALL DIMENSIONS ARE APPROXIMATE AND SUBJECT TO CHANGE UNLESS CERTIFIED.
  2. SEE MANUAL FOR COMPLETE SPECIFICATIONS, CAPACITIES, INSTALLATION, OPERATION & MAINTENANCE INSTRUCTIONS, & SAFETY PRECAUTIONS.
  3. PROVIDE MINIMUM 4" ON EACH SIDE OF DRYER AND OVERHEAD FOR SERVICE AND MAINTENANCE.
  4. DO NOT OPERATE WITHOUT PROPER PURGE FLOW.
  5. BYPASS VALVES MUST BE BUBBLE TIGHT.
  6. DO NOT SURGE DESICCANT BED OR FILTERS.
  7. CAPACITY AND SIZING BASED ON CAGI STANDARD, 100 °F INLET, 100 PSI INLET, 68 °F AMBIENT.

APPROXIMATE WEIGHT	5500 LB.	NEMA RATING	4	PURGE FLOW	240 CFM
DESICCANT AMOUNT	2000 LB.	CONTROLS	BASIC	PURGE SET PRESSURE	51 PSIG
FILLED	YES	CONTROL TUBING	NYLON	PAINT	RENTAL LAGATE GRAY

PROPERTY OF PARKER HANNIFIN CORPORATION  
 THIS DOCUMENT CONTAINS INFORMATION THAT IS CONFIDENTIAL AND PROPRIETARY TO PARKER HANNIFIN CORPORATION. IT IS TO BE USED ONLY FOR THE PURPOSES SPECIFIED HEREIN. IT IS NOT TO BE REPRODUCED, COPIED, OR DISCLOSED TO OTHERS WITHOUT THE WRITTEN PERMISSION OF PARKER HANNIFIN CORPORATION. ALL RIGHTS ARE RESERVED BY PARKER HANNIFIN CORPORATION. © 2020

MATERIAL	PPD1600BN	DRYER	AIR DRYER
PART NUMBER	PPD1600BN	DRYER NUMBER	PPD1600BN
JOB NUMBER:	DATE:	REVIEWED BY:	DATE:





ECO NO.		REVISION HISTORY		DATE		APPROVED	
0355519		UPDATE CONTROL PANEL FRAME		2/23/21		JZ	

PPD3000BN		MOTOR HP		120	
MAX PSI	150 PSIG	VOLT	120	MOTOR HP	N/A
MIN PSI	100 PSIG	PHASE	1	MOTOR FLA	N/A
CAPACITY	3000 CFM	HZ	50/60	AMPS	N/A
INLET AIR	120 °F	DRYER FLA	2		
OUTLET AIR	150 °F	MIN CIRCUIT	N/A		
AMBIENT AIR	40 °F	AMPACITY	N/A		
MIN TEMP		MAX FUSE	N/A		
MAX TEMP	120 °F	SCCR	N/A		

EQUIPMENT SUITABLE FOR OUTDOOR  MIN SPACING TO COMBUSTIBLE  SURFACE  
USE ONLY IF CHECKED

**NOTES:**

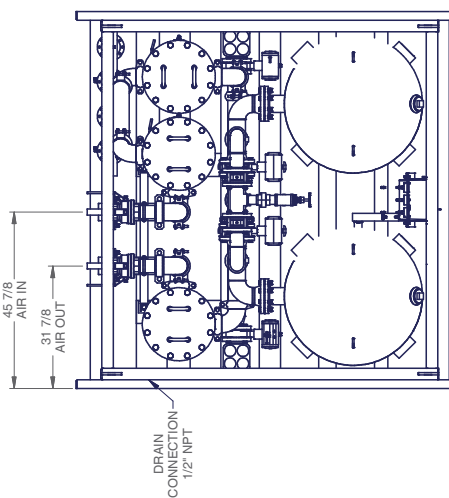
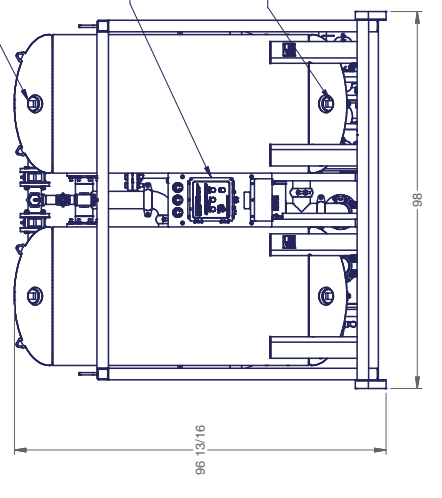
1. ALL DIMENSIONS ARE APPROXIMATE AND SUBJECT TO CHANGE UNLESS CERTIFIED.
2. SEE MANUAL FOR COMPLETE SPECIFICATIONS, CAPACITIES, INSTALLATION, OPERATION & MAINTENANCE INSTRUCTIONS, & SAFETY PRECAUTIONS.
3. PROVIDE MINIMUM 4" ON EACH SIDE OF DRYER AND OVERHEAD FOR SERVICE AND MAINTENANCE.
4. DO NOT OPERATE WITHOUT PROPER PURGE FLOW.
5. BYPASS VALVES MUST BE BUBBLE TIGHT.
6. DO NOT SURGE DESICCANT BED OR FILTERS.
7. CAPACITY AND SIZING BASED ON CAGI STANDARD, 100 °F INLET, 100 PSI INLET, 68 °F AMBIENT.

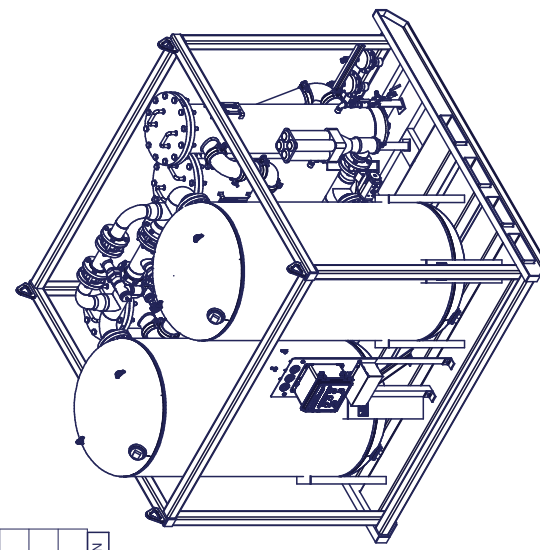
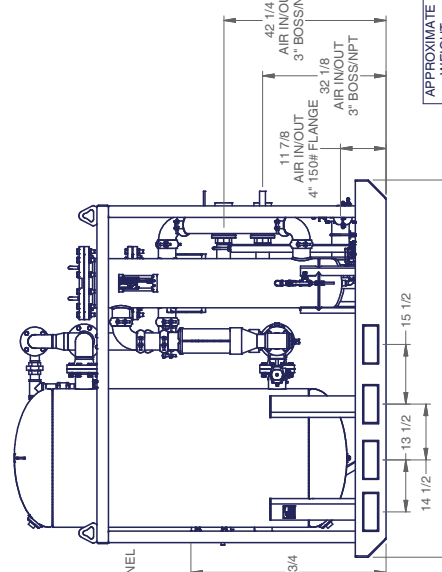
APPROXIMATE WEIGHT	NEWA RATING	PURGE FLOW
10150 LB.	4	450 CFM
DESICCANT AMOUNT	BASIC CONTROLS	PURGE SET PRESSURE
3600 LB.	NYLON	38 PSIG
FILLED	CONTROL	RENTAL PAINT
YES	NYLON	AGATE GRAY

**PROPERTY OF PARKER HANFMAN**

THIS DOCUMENT CONTAINS INFORMATION THAT IS UNCLASSIFIED AND UNCONTROLLED UNLESS INDICATED OTHERWISE. IT IS THE PROPERTY OF PARKER HANFMAN AND IS LOANED TO YOU BY PARKER HANFMAN. IT IS NOT TO BE REPRODUCED OR TRANSMITTED IN ANY FORM OR BY ANY MEANS, ELECTRONIC OR MECHANICAL, INCLUDING PHOTOCOPYING, RECORDING, OR BY ANY INFORMATION STORAGE AND RETRIEVAL SYSTEM. ALL INFORMATION IS CONFIDENTIAL AND NOT TO BE DISCLOSED TO OTHERS WITHOUT THE WRITTEN PERMISSION OF PARKER HANFMAN. UNAUTHORIZED DISCLOSURE IS PROHIBITED AND WILL BE PUNISHED AS A VIOLATION OF COMPANY POLICY.

DATE: 02/23/2021  
UNIT: INCHES

**TITLE** GENERAL ARRANGEMENT: RENTAL DESICCANT AIR DRYER

**SIZE** 1 OF 1

**DRAWING NUMBER** PPD3000BN

**REVISION** A





# 11.0 Electrical Schematics

REVISION HISTORY		DATE	APPROVED
ECO NO.	REV	DESCRIPTION	DATE
0356834	C	PRODUCTION RELEASE	2/25/2021
		RJM	

**NOTES:**

1. ALL WIRES ARE DRAWN UNLESS OTHERWISE NOTED.
2. VALVE CABLES HAVE LED INDICATORS AND INTERNAL NOISE SUPPRESSORS
3. VALVE CABLES HAVE LED INDICATORS AND INTERNAL NOISE SUPPRESSORS
4. FUSE (F1) IS INTERNALLY PROTECTED WITH 3.15A FUSE (NON-SERVICEABLE)
5. O INDICATES SPICE CONNECTION

**PROPERTY OF PARKER HANIFIN CORPORATION**  
 PARKER HANIFIN AND IS FURNISHED ON THE UNDERSTANDING THAT THIS DOCUMENT AND PROPRIETARY TO PARKER HANIFIN. IT IS NOT TO BE REPRODUCED OR TRANSMITTED IN ANY FORM OR BY ANY MEANS, ELECTRONIC OR MECHANICAL, INCLUDING PHOTOCOPYING, RECORDING, OR BY ANY INFORMATION STORAGE AND RETRIEVAL SYSTEM, WITHOUT THE WRITTEN PERMISSION OF PARKER HANIFIN. THIS DOCUMENT IS THE PROPERTY OF PARKER HANIFIN AND WILL BE RETURNED AND ALL FURTHER USE DISCONTINUED UPON REQUEST BY PARKER HANIFIN. THE USER SHALL BE RESPONSIBLE FOR OBTAINING ALL NECESSARY PERMITS AND APPROVALS FOR ANY MODIFICATIONS TO THIS DOCUMENT.

**USE CORRESPONDING TOLERANCES UNLESS OTHERWISE SPECIFIED**

MATERIAL	PROPERTY OF PARKER HANIFIN CORPORATION	DATE	REVISION
	THIS DOCUMENT CONTAINS INFORMATION THAT IS CONFIDENTIAL AND PROPRIETARY TO PARKER HANIFIN. IT IS NOT TO BE REPRODUCED OR TRANSMITTED IN ANY FORM OR BY ANY MEANS, ELECTRONIC OR MECHANICAL, INCLUDING PHOTOCOPYING, RECORDING, OR BY ANY INFORMATION STORAGE AND RETRIEVAL SYSTEM, WITHOUT THE WRITTEN PERMISSION OF PARKER HANIFIN. THIS DOCUMENT IS THE PROPERTY OF PARKER HANIFIN AND WILL BE RETURNED AND ALL FURTHER USE DISCONTINUED UPON REQUEST BY PARKER HANIFIN. THE USER SHALL BE RESPONSIBLE FOR OBTAINING ALL NECESSARY PERMITS AND APPROVALS FOR ANY MODIFICATIONS TO THIS DOCUMENT.	3/15/2020	C

DRAWING NUMBER		DATE	REVISION
DRAWING NUMBER	DATE	REVISION	DATE
TP2656	3/15/2020	C	2/25/2021

JOB NUMBER:		DATE:

REVIEWED BY:		DATE:

PART NUMBER		DATE	REVISION
PART NUMBER	DATE	REVISION	DATE
TP2656	3/15/2020	C	2/25/2021

TITLE		DATE	REVISION
TITLE	DATE	REVISION	DATE
PPD RENTAL DRYERS - CONTROL ASSEMBLY	3/15/2020	C	2/25/2021

DRAWING NUMBER		DATE	REVISION
DRAWING NUMBER	DATE	REVISION	DATE
TP2656	3/15/2020	C	2/25/2021

SHEET		DATE	REVISION
SHEET	DATE	REVISION	DATE
7 OF 17	3/15/2020	C	2/25/2021

SIZE		DATE	REVISION
SIZE	DATE	REVISION	DATE
B	3/15/2020	C	2/25/2021

MATERIAL		DATE	REVISION
MATERIAL	DATE	REVISION	DATE
TP2656	3/15/2020	C	2/25/2021

  

MATERIAL		DATE	REVISION
MATERIAL	DATE	REVISION	DATE
TP2656	3/15/2020	C	2/25/2021

MATERIAL		DATE	REVISION
MATERIAL	DATE	REVISION	DATE
TP2656	3/15/2020	C	2/25/2021



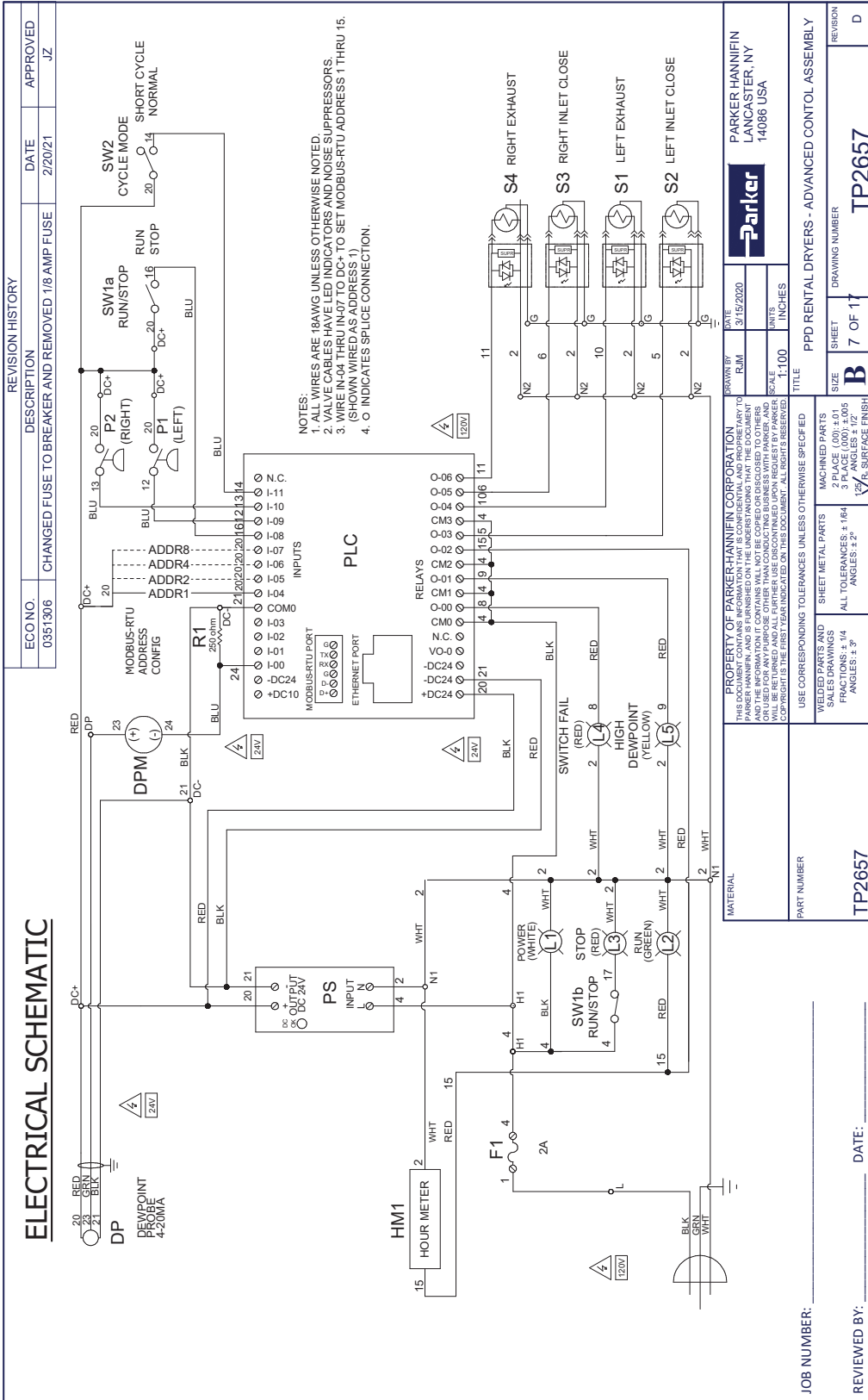

## 12.0 Disposal of Equipment

Disposal of PPD dryers, their individual components and/or desiccant material should be done in a manner that protects the environment and complies with all applicable Federal, State and local regulation.

12.1 Desiccant SDS

Safety Data Sheet

Product Identifier: AXSORB-D

SDS ID: LP3-AXSORB-D

\*\*\* Section 1 - Identification\*\*\*

Product Identifier: AXSORB-D  
 Product Code: 22600  
 Chemical Name: Alumina  
 Product Use: Activated alumina.

Supplier Details of the Safety Data Sheet

Axens North America, Inc.  
 1800 St. James Place  
 Suite 500  
 Houston, TX 77056

Phone: 713-840-1133  
 Fax: 713-840-8375  
 Emergency # 3E Company 1-866-519-4752

\*\*\* Section 2 - Hazard(s) Identification \*\*\*

Classification in accordance with 29 CFR 1910.1200.

- Skin Corrosion / Irritation, Category 2
- Eye Damage / Irritation, Category 2A
- Specific Target Organ Toxicity - Single Exposure, Category 3 (respiratory tract irritation)
- Specific Target Organ Toxicity - Repeated Exposure, Category 1 (respiratory system)

GHS LABEL ELEMENTS

Symbol(s)



Signal Word

DANGER

Hazard Statement(s)

- Causes skin irritation.
- Causes serious eye irritation.
- May cause respiratory irritation.
- Causes damage to respiratory system through prolonged or repeated exposure.

Precautionary Statement(s)

Prevention

Do not breathe dust. Wash thoroughly after handling. Wear protective gloves and eye/face protection. Do not eat, drink or smoke when using this product. Use only outdoors or in a well-ventilated area.

Response

Get medical advice/attention if you feel unwell. IF INHALED: Remove person to fresh air and keep comfortable for breathing. Call a POISON CENTER or doctor/physician if you feel unwell. IF ON SKIN: Wash with plenty of water. If skin irritation occurs: Get medical advice/attention. Take off contaminated clothing and wash it before reuse. IF IN EYES: Rinse cautiously with water for several minutes. Remove contact lenses, if present and easy to do. Continue rinsing. If eye irritation persists: Get medical advice/attention.

Storage

Store locked up. Store in a well-ventilated place. Keep container tightly closed.



## Safety Data Sheet

Product Identifier: AXSORB-D

SDS ID: LP3-AXSORB-D

**Disposal**

Dispose in accordance with all applicable federal, state/regional and local laws and regulations.

**\*\*\* Section 3 - COMPOSITION / INFORMATION ON INGREDIENTS \*\*\***

CAS	Component	Percent
1344-28-1	Aluminum oxide (non-fibrous)	95-100
1313-59-3	Sodium oxide	0.1-1

**Component Related Regulatory Information**

This product may be regulated, have exposure limits or other information identified as the following: Aluminum (7429-90-5).

**\*\*\* Section 4 - First Aid Measures \*\*\***
**Description of Necessary Measures****Inhalation**

Remove person to fresh air and keep comfortable for breathing. Call a POISON CENTER or doctor/physician if you feel unwell.

**Skin Contact**

Wash with plenty of soap and water. If skin irritation occurs: Get medical advice/attention. Take off contaminated clothing and wash it before reuse.

**Eye Contact**

Rinse cautiously with water for several minutes. Remove contact lenses, if present and easy to do. Continue rinsing. If eye irritation persists, get medical advice/attention.

**Ingestion**

If a large amount is ingested, seek medical attention. Do not induce vomiting.

**Most Important Symptoms/Effects****Acute**

respiratory tract irritation, skin irritation, eye irritation

**Delayed**

respiratory system effects

**Indication of immediate Medical Attention and Special Treatment**

Treat symptomatically and supportively.

**\*\*\* Section 5 - Fire Fighting Measures \*\*\***
**Suitable Extinguishing Media**

Use methods for the surrounding fire.

**Unsuitable Extinguishing Media**

None known.

**Specific Hazards Arising from the Chemical**

Not a fire hazard.

**Hazardous Combustion Products**

Non-combustible, substance itself does not burn.

**Special Protective Equipment and Precautions for Firefighters**

Firefighters should wear full protective clothing including self contained breathing apparatus.

**Fire Fighting Measures**

Move container from fire area if it can be done without risk. Cool containers with water spray until well after the fire is out. Stay upwind and keep out of low areas.

## Safety Data Sheet

Product Identifier: AXSORB-D

SDS ID: LP3-AXSORB-D

### \*\*\* Section 6 - ACCIDENTAL RELEASE MEASURES \*\*\*

#### Personal Precautions, Protective Equipment and Emergency Procedures

Avoid breathing dust. Wear appropriate protective equipment and clothing during clean-up.

#### Methods and Materials for Containment and Cleaning Up

Stop the flow of material, if this is without risk. Contain the discharged material. Sweep up or gather material and place in appropriate container for disposal. If sweeping of a contaminated area is necessary, use a dust suppressant agent. Flush area with water to remove trace residue. Follow all Local, State, Federal and Provincial regulations for disposal. Isolate area. Keep unnecessary personnel away.

### \*\*\* Section 7 - HANDLING AND STORAGE \*\*\*

#### Precautions for Safe Handling

Do not breathe dust. Do not eat, drink, or smoke when using this product. Use only with adequate ventilation. Wash thoroughly after handling. Use personal protective equipment as required. Avoid dust generation and accumulation. Routine housekeeping should be instituted to ensure that dusts do not accumulate on surfaces.

#### Condition for Safe storage, Including any incompatibilities

Store in original container. Store in area of low relative humidity. Keep container tightly closed and in a well-ventilated place. Keep in a cool place. Keep away from incompatible materials.

#### Incompatibilities

Incompatible materials include strong acids, strong bases, and strong oxidizing materials.

### \*\*\* Section 8 - EXPOSURE CONTROLS/ PERSONAL PROTECTION \*\*\*

#### Component Exposure Limits

Consult local authorities for acceptable exposure limits.

##### Aluminum oxide (1344-28-1)

<b>ACGIH:</b>	1 mg/m <sup>3</sup> TWA (respirable fraction, related to Aluminum)
<b>OSHA Vacated:</b>	10 mg/m <sup>3</sup> TWA (total dust); 5 mg/m <sup>3</sup> TWA (respirable fraction)
<b>OSHA Final:</b>	15 mg/m <sup>3</sup> TWA (total dust); 5 mg/m <sup>3</sup> TWA (respirable fraction)
<b>NIOSH:</b>	10 mg/m <sup>3</sup> TWA (total dust); 5 mg/m <sup>3</sup> TWA (respirable dust, related to Aluminum)
<b>Alberta:</b>	10 mg/m <sup>3</sup> TWA
<b>British Columbia:</b>	1.0 mg/m <sup>3</sup> TWA (respirable, related to Aluminum)
<b>Manitoba:</b>	1 mg/m <sup>3</sup> TWA (respirable fraction, related to Aluminum)
<b>New Brunswick:</b>	10 mg/m <sup>3</sup> TWA (particulate matter containing no Asbestos and <1% Crystalline silica)
<b>NW Territories:</b>	10 mg/m <sup>3</sup> TWA; 5 mg/m <sup>3</sup> TWA (respirable mass); 10 mg/m <sup>3</sup> TWA (total mass) 20 mg/m <sup>3</sup> STEL
<b>Nova Scotia:</b>	1 mg/m <sup>3</sup> TWA (respirable fraction, related to Aluminum)
<b>Nunavut:</b>	10 mg/m <sup>3</sup> TWA; 5 mg/m <sup>3</sup> TWA (respirable mass); 10 mg/m <sup>3</sup> TWA (total mass) 20 mg/m <sup>3</sup> STEL
<b>Ontario:</b>	1 mg/m <sup>3</sup> TWA (respirable, related to Aluminum)
<b>Quebec:</b>	10 mg/m <sup>3</sup> TWAEV (containing no Asbestos and <1% Crystalline silica, as Al, total dust)
<b>Saskatchewan:</b>	10 mg/m <sup>3</sup> TWA 20 mg/m <sup>3</sup> STEL
<b>Yukon:</b>	30 mppcf TWA (Al <sub>2</sub> O <sub>3</sub> ); 10 mg/m <sup>3</sup> TWA (Al <sub>2</sub> O <sub>3</sub> ) 20 mg/m <sup>3</sup> STEL (Al <sub>2</sub> O <sub>3</sub> )

#### Appropriate Engineering Controls

Ventilation should effectively remove and prevent buildup of any dust generated from the handling of this product. If necessary, use appropriate local exhaust ventilation to keep exposures below the regulated limits.

#### Individual Protection Measures, such as Personal Protective Equipment

##### Eyes/Face Protection

Wear safety glasses with side shields.

## Safety Data Sheet

Product Identifier: AXSORB-D

SDS ID: LP3-AXSORB-D

**Skin Protection**

Wear chemical resistant gloves. Work clothing sufficient to prevent all skin contact should be worn, such as coveralls and long sleeves. Launder contaminated clothing before reuse.

**Respiratory Protection**

If ventilation is not sufficient to effectively prevent buildup of dust, appropriate NIOSH approved respiratory protection must be provided.

**Gloves recommendations**

Wear chemical resistant gloves.

**General Information**

Eye wash fountain and emergency showers are recommended. Use in accordance with good industrial hygiene practices.

**\*\*\* Section 9 - PHYSICAL AND CHEMICAL PROPERTIES \*\*\***

<b>Appearance:</b> Solid granules <b>Physical State:</b> Solid <b>Vapor Pressure:</b> Not Applicable <b>Boiling Point:</b> Not Applicable <b>Solubility (H2O):</b> Insoluble <b>Flash Point Method:</b> Not Available <b>Auto Ignition:</b> Not Available <b>UFL:</b> Not Available <b>Evaporation Rate:</b> Not Available <b>Bulk Density:</b> <1 <b>Decomposition Temperature:</b> Not Available	<b>Odor:</b> None <b>pH:</b> Not Determined <b>Vapor Density:</b> Not Applicable <b>Melting Point:</b> 2000°C <b>Flash Point:</b> Not Available <b>Flamm Class:</b> Not Available <b>LFL:</b> Not Available <b>Specific Gravity:</b> Not Available <b>Viscosity:</b> Not Applicable <b>Octanol/H2O Coeff.:</b> Not Available
--	---

**\*\*\* Section 10 - Chemical Stability & Reactivity Information \*\*\***
**Reactivity**

No reactivity hazard is expected.

**Chemical Stability**

Stable at normal temperatures and pressure.

**Possibility of Hazardous Reactions**

Will not occur.

**Conditions to Avoid**

Avoid generating dust. Avoid dispersion of dust in air.

**Incompatible Materials**

Incompatible materials include strong acids, strong bases, and strong oxidizing materials.

**Hazardous Decomposition Products**

Irritating and/or toxic fumes and gases may be emitted upon the product's decomposition.

**\*\*\* Section 11 - TOXICOLOGICAL INFORMATION \*\*\***
**Acute Toxicity**

May cause respiratory tract irritation. May cause irritation of the skin and eyes.

Aluminum: Excessive inhalation of aluminum dust may cause pulmonary fibrosis, and has been associated with neurological disorders. Ingestion is reported to cause elevated blood levels of aluminum, and is reported to cause behavioral changes in experimental animals.

**Component Analysis - LD50/LC50****Aluminum oxide (1344-28-1)**

Oral LD50 Rat >5000 mg/kg

## Safety Data Sheet

Product Identifier: AXSORB-D

SDS ID: LP3-AXSORB-D

**Chronic Toxicity**

Prolonged skin exposure may cause irritation and/or dermatitis. Repeated or prolonged contact may result in conjunctivitis. Repeated or prolonged exposure may cause respiratory system effects.

**ROUTES OF EXPOSURE****Inhalation**

Dust may cause irritation of the nose and throat, respiratory tract. Repeated or prolonged exposure may cause respiratory system effects.

**Ingestion**

Ingestion of large amounts of product may produce nausea, vomiting, and/or diarrhea.

**Skin**

May cause irritation. Prolonged skin exposure may cause irritation and/or dermatitis.

**Eyes**

May cause irritation. Repeated or prolonged contact may result in conjunctivitis.

**Immediate Effects**

respiratory tract irritation, skin irritation, eye irritation

**Delayed Effects**

respiratory system effects

**Medical Conditions Aggravated by Exposure**

respiratory disorders

**Irritation/Corrosivity Data**

respiratory tract irritation, skin irritation, eye irritation

**Respiratory Sensitization**

No information available for the product.

**Dermal Sensitization**

No information available for the product.

**Germ Cell Mutagenicity**

No information available for the product.

**Carcinogenicity****Component Carcinogenicity****Aluminum oxide (1344-28-1)**

ACGIH: A4 - Not Classifiable as a Human Carcinogen (related to Aluminum)

**Reproductive Toxicity**

No information available for the product.

**Specified Target Organ Toxicity - Single Exposure**

respiratory system

**Specified Target Organ Toxicity - Repeated Exposure**

respiratory system

**Aspiration Hazard**

No data available.

**\*\*\*Section 12 - ECOLOGICAL INFORMATION\*\*\***

**Ecotoxicity**

No information is available for the material as a tested mixture.

**Component Analysis - Ecotoxicity - Aquatic Toxicity**

No ecotoxicity data are available for this product's components.

**Persistence & Degradability**

Biodegradable, but not readily (rapidly).

**Bioaccumulation**

No information available for the product.



## Safety Data Sheet

Product Identifier: AXSORB-D

SDS ID: LP3-AXSORB-D

**Mobility**

Partly dissolves, but significant proportion will remain after one day. If product enters soil, one or more constituents will be mobile and may contaminate groundwater.

\*\*\* Section 13 - DISPOSAL CONSIDERATIONS \*\*\*

**Disposal Methods**

As supplied, this material is not expected to be a characteristic hazardous waste under RCRA. However, this may not be true following use or modification of the original product. Wastes must be tested using methods described in 40 CFR Part 261 to determine if it meets applicable definitions of hazardous wastes. Dispose of in accordance with all applicable federal, state and local regulations.

See Section 7 for Handling Procedures. See Section 8 for Personal Protective Equipment recommendations.

**US EPA Waste Number & Descriptions**

**Component Waste Numbers**

No EPA Waste Numbers are applicable for this product's components.

**Disposal of Contaminated Packaging**

Reuse or recycle if possible. Dispose of in accordance with all applicable federal, state and local regulations.

\*\*\* Section 14 - Transportation Information \*\*\*

**US DOT Information**

Not regulated as a hazardous material.

**TDG Information**

Not regulated as dangerous goods.

\*\*\* Section 15 - REGULATORY INFORMATION \*\*\*

**U.S. Federal Regulations**

**Component Analysis**

This material contains one or more of the following chemicals required to be identified under SARA Section 302 (40 CFR 355 Appendix A), SARA Section 313 (40 CFR 372.65) and/or CERCLA (40 CFR 302.4).

**SARA 311/312 Hazardous Categories (40 CFR 370 Subparts B and C)**

Acute Health: Yes Chronic Health: Yes Fire: No Pressure: No Reactive: No

**U.S. State Regulations**

**Component Analysis - State**

The following components appear on one or more of the following state hazardous substances lists:

Component	CAS	CA	MA	MN	NJ	PA
Aluminum oxide	1344-28-1	Yes	Yes	Yes	Yes	Yes

This product does not contain any components listed on the California Safe Drinking Water and Toxic Enforcement Act of 1986 (Prop 65).

**Canadian WHMIS Information**

This product has been classified in accordance with the criteria of the Controlled Products Regulations (CPR) and the MSDS contains all of the information required by the CPR.

**WHMIS Classification:** D2B- Irritating to eyes and skin.

**Component Analysis - WHMIS IDL**

The following components are identified under the Canadian Hazardous Products Act Ingredient Disclosure List:

**Aluminum oxide (1344-28-1)**

1 %

**CEPA - Canadian Environmental Protection Act**

This product does not contain any toxic substances requiring export notification in part II of schedule III of the Canadian Environmental Protection Act.



## Safety Data Sheet

Product Identifier: AXSORB-D

SDS ID: LP3-AXSORB-D

**Additional Regulatory Information**  
**Component Analysis - Inventory**

Component	CAS #	TSCA	CAN	EEC
Aluminum oxide	1344-28-1	Yes	DSL	EIN
Sodium oxide	1313-59-3	Yes	DSL	EIN

**\*\*\* Section 16 - OTHER INFORMATION \*\*\***

**NFPA Ratings: Health: 2 Fire: 0 Reactivity: 0**  
 Hazard Scale: 0 = Minimal 1 = Slight 2 = Moderate 3 = Serious 4 = Severe

**HMIS Ratings: Health: 2\* Fire: 0 Reactivity: 0**  
 Hazard Scale: 0 = Minimal 1 = Slight 2 = Moderate 3 = Serious 4 = Severe \* = Chronic hazard

**Key/Legend**

ACGIH = American Conference of Governmental Industrial Hygienists. CERCLA = Comprehensive Environmental Response, Compensation and Liability Act. CFR = Code of Federal Regulations. DSL = Canadian Domestic Substance List. EINECS = European Inventory of New and Existing Chemical Substances. EPA = Environmental Protection Agency. HEPA = High Efficiency Particulate Air. HMIS = Hazardous Material Identification System. IARC = International Agency for Research on Cancer. NFPA = National Fire Protection Association. NIOSH = National Institute of Occupational Safety and Health. NJTSR = New Jersey Trade Secret Registry. NTP = National Toxicology Program. OSHA = Occupational Safety and Health Administration. NA = Not available or Not Applicable. SARA = Superfund Amendments and Reauthorization Act. TLV = Threshold Limit Value. TSCA = Toxic Substance Control Act. WHMIS = Workplace Hazardous Materials Information System.

**MSDS History**

Revision 1.0000, 18 July 2013: New SDS.

**Other Information**

Disclaimer: Supplier gives no warranty of merchantability or of fitness for a particular purpose. Any product purchased is sold on the assumption the purchaser will make his own tests to determine the quality and suitability of the product. Supplier expressly disclaims any and all liability for incidental and/or consequential property damage arising out of the use of this product. No information provided shall be deemed to be a recommendation to use any product in conflict with any existing patent rights. Read the Material Safety Data Sheet before handling product.

End of Sheet LP3-AXSORB-D



Page intentionally left blank

# Worldwide Filtration Manufacturing Locations

## North America

### Compressed Air Treatment

#### Industrial Gas Filtration and Generation Division

Lancaster, NY  
716 686 6400  
[www.parker.com/igfg](http://www.parker.com/igfg)

Haverhill, MA  
978 858 0505  
[www.parker.com/igfg](http://www.parker.com/igfg)

### Engine Filtration

#### Racor

Modesto, CA  
209 521 7860  
[www.parker.com/racor](http://www.parker.com/racor)

Holly Springs, MS  
662 252 2656  
[www.parker.com/racor](http://www.parker.com/racor)

### Hydraulic Filtration

#### Hydraulic & Fuel Filtration

Metamora, OH  
419 644 4311  
[www.parker.com/hydraulicfilter](http://www.parker.com/hydraulicfilter)

Laval, QC Canada  
450 629 9594  
[www.parkerfarr.com](http://www.parkerfarr.com)

Velcon  
Colorado Springs, CO  
719 531 5855  
[www.velcon.com](http://www.velcon.com)

### Process Filtration

#### domnick hunter Process Filtration SciLog

Oxnard, CA  
805 604 3400  
[www.parker.com/processfiltration](http://www.parker.com/processfiltration)

### Water Purification

#### Village Marine, Sea Recovery, Horizon Reverse Osmosis

Carson, CA  
310 637 3400  
[www.parker.com/watermakers](http://www.parker.com/watermakers)

## Europe

### Compressed Air Treatment

#### domnick hunter Filtration & Separation

Gateshead, England  
+44 (0) 191 402 9000  
[www.parker.com/dhfns](http://www.parker.com/dhfns)

#### Parker Gas Separations

Etten-Leur, Netherlands  
+31 76 508 5300  
[www.parker.com/dhfns](http://www.parker.com/dhfns)

#### Hiross Zander

Essen, Germany  
+49 2054 9340  
[www.parker.com/hzfd](http://www.parker.com/hzfd)

Padova, Italy  
+39 049 9712 111  
[www.parker.com/hzfd](http://www.parker.com/hzfd)

### Engine Filtration & Water Purification

#### Racor

Dewsbury, England  
+44 (0) 1924 487 000  
[www.parker.com/rfde](http://www.parker.com/rfde)

#### Racor Research & Development

Stuttgart, Germany  
+49 (0)711 7071 290-10

### Hydraulic Filtration

#### Hydraulic Filter

Arnhem, Holland  
+31 26 3760376  
[www.parker.com/hfde](http://www.parker.com/hfde)

Ujala, Finland  
+358 20 753 2500

#### Condition Monitoring Parker Kittiwake

West Sussex, England  
+44 (0) 1903 731 470  
[www.kittiwake.com](http://www.kittiwake.com)

### Process Filtration

#### domnick hunter Process Filtration Parker Twin Filter BV

Birtley, England  
+44 (0) 191 410 5121  
[www.parker.com/processfiltration](http://www.parker.com/processfiltration)

## Asia Pacific

### Australia

Castle Hill, Australia  
+61 2 9634 7777  
[www.parker.com/australia](http://www.parker.com/australia)

### China

Shanghai, China  
+86 21 5031 2525  
[www.parker.com/china](http://www.parker.com/china)

### India

Chennai, India  
+91 22 4391 0700  
[www.parker.com/india](http://www.parker.com/india)

### Parker Fowler

Bangalore, India  
+91 80 2783 6794  
[www.johnfowlerindia.com](http://www.johnfowlerindia.com)

### Japan

Tokyo, Japan  
+81 45 870 1522  
[www.parker.com/japan](http://www.parker.com/japan)

### Korea

Hwaseon-City  
+82 31 359 0852  
[www.parker.com/korea](http://www.parker.com/korea)

### Singapore

Jurong Town, Singapore  
+65 6887 6300  
[www.parker.com/singapore](http://www.parker.com/singapore)

### Thailand

Bangkok, Thailand  
+66 2186 7000  
[www.parker.com/thailand](http://www.parker.com/thailand)

## Latin America

### Parker Comercio Ltda.

Filtration Division  
Sao Paulo, Brazil  
+55 12 4009 3500  
[www.parker.com/br](http://www.parker.com/br)

### Pan American Division

Miami, FL  
305 470 8800  
[www.parker.com/panam](http://www.parker.com/panam)

## Africa

Aeroport Kempton Park, South Africa  
+27 11 9610700  
[www.parker.com/africa](http://www.parker.com/africa)

